



174p



175p



175p



176p



176p



177p



178p



178p



179p



179p



180p



180p



181p



182p



183p



185p



185p



186p



186p



187p



187p



188p

ANGLE



188p



189p



189p



190p



191p

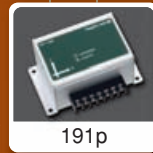

191p



192p



192p



193p



193p



194p



194p



194p



195p



196p



196p



196p



196p



196p



196p



196p



196p



197p



197p

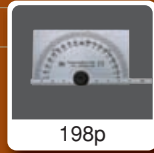

198p



198p



198p



198p



199p



199p



199p



199p



200p

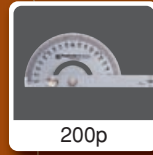

200p



200p



200p



201p



201p



201p



202p



202p

LEVELNIC
PRECISION
LEVEL
ANGLE
LEVEL
LEVEL
PROTRA
CTOR



ANGLE

07

ANGLE

LEVELNIC

PRECISION LEVEL

ANGLE LEVEL

LEVEL

PROTRACTOR

Angle Measurement Specifications Summary

※ Refer to the page listed for each item for detailed specifications

	Product Name	Model No.	Measuring Range	Minimum Reading	Page
DIGITAL LEVEL	LEVELNIC	DL-S3 · DL-S3C · DL-S3L	± 5.00mm/m · ± 0.286°	0.001mm/m · ± 0.0001°	173 · 174
	LEVELNIC	DL-S2W	± 5.000mm/m · ± 0.2865°	0.001mm/m · ± 0.0001°	177
	LEVELNIC	DL-m1	± 5.00mm/m	0.01mm/m	179
	LEVELNIC	DL-m3 · DL-m3LS	± 5.00mm/m	0.01mm/m	179 · 180
	SEPARATE SYSTEM	DL-S2+ · DL-D3	± 5.000mm/m · ± 0.2865°	0.001mm/m · ± 0.0001°	181
	LEVELNIC	DL-S1	± 9.99mm/m	0.01mm/m	182
LEVEL	LEVELNIC	EL-01A	± 0.2mm/m ± 1mm/m ± 2mm/m	"0.01mm/m 0.05mm/m 0.1mm/m"	183
DIGITAL ANGLE LEVEL	DIGITAL ANGLE GAUGE	DP-10XY	± 9.99°	0.01° (in sensor mode : 0.002°)	190
	DIGITAL ANGLE GAUGE	DP-10S · DP-10D SET	± 9.99°	0.01° (in sensor mode : 0.002°)	191
	DIGITAL LEVEL SENSOR	DP-10M	± 9.998°	0.002°	191
	DIGITAL PROTRACTOR	DP-50	± 50°	0.1°	189
	DIGITAL PROTRACTOR	DP-90	± 90°	1mm/m · 0.05° · 0.1%	189
	BEVEL BOX	BB-180	± 180.0°	0.1°	192
	BEVEL BOX	BB-180A	± 180.0°	0.1°	192
ANGLE LEVEL	LEVEL METER	LM-90	0 ~ 90°	1°	193
	LEVEL MATE	LM-360	0 ~ 360°	1°	193
	DIAL SLANT RULE	DSR-ST · DSR-MG	0 ~ 180°	1°	194
	LEVEL POINT GAUGE	LP-360	0 ~ 360°	1°	194
PROTRACTOR	PROTRACTOR No.15	PRT-15	180°	1°	198
	PROTRACTOR No.19 Satin finish	PRT-19	180°	1°	198
	PROTRACTOR No.19 Polished finish	PRT-19S	180°	1°	198
	PROTRACTOR No.19 with 2 blades	PRT-19SW	180°	1°	198
	PROTRACTOR No.19A	PRT-19A	90°	1°	199
	PROTRACTOR No.19B	PRT-19B	180°	1°	199
	PROTRACTOR No.182	PRT-182S	180°	1°	199
	PROTRACTOR No.183	PRT-183S	180°	1°	199
	PROTRACTOR No.30	PRT-30S	180°	1°	200
	PROTRACTOR No.101	PRT-101S	180°	1°	200
	PROTRACTOR No.300	PRT-300S · PRT-300SW	180°	0.5°	200
	PROTRACTOR No.400	PRT-400S · PRT-400SW	180°	0.5°	200
	PROTRACTOR No.600	PRT-600S · PRT-600SW	180°	0.5°	200
	PROTRACTOR No.1000	PRT-1000S · PRT-1000SW	180°	0.5°	200
	INSIDE PROTRACTOR	IP-90	10° ~ 90°	1°	201
	PROTRACTOR No.192	PRT192-90S · 120S	180°	1°	201
	PROTRACTOR No.192	PRT192-200S · 250S · 300S	180°	0.5°	201
PROTRACTOR No.193	PRT193- □	360°	1°	201	
UNIVERSAL BEVEL PROTRACTOR	495D	360°	5"	202	
DIGITAL UNIVERSAL BEVEL PROTRACTOR	DUP-360	360°	30" (0.008°)	202	
ANGLE GAUGE	ANGLE GAUGE	WGA-65	25 ~ 65° 70 ~ 110°	0.5° 1°	161
	ANGLE PROTRACTOR	AP-130	30 ~ 130° · 0 ~ 90° · 0 ~ 180°	1°	161

Levelnic principles of operation

The role of "0 adjustment", and "1/2 adjustment".

Levelnic, like every level, is an instrument which is sensitive to its position relative to earth's gravity. The operation is as follows.

We can show how we determine true horizontal using the following method. On a slope, put a board with a weight suspended by a string. The weight will hang at an angle of θ from a line perpendicular to the slope. If the board is rotated 180° , the weight will hang at the same angle θ from a line perpendicular to the slope. Without having an absolute reference, we can determine the angle 2θ by rotating our instrument 180° and measuring the total change in angle relative our perpendicular reference. We can thereby determine θ if we divide by two. Also notice that the angle of the slope relative to true horizontal is also θ . If we set zero with the level on a slope, when we rotate the level 180° the reading will be twice the actual angle of the slope. If we then adjust the slope of the surface being measured (the device under test) until the angle reading is reduced to $1/2$ of that value, the surface will be horizontal. Conversely, some desire having an absolute standard only because of confusion or misunderstanding regarding the above process.

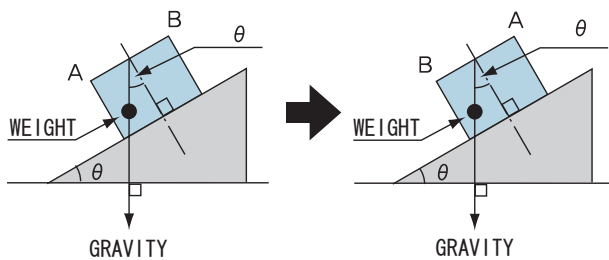

※DL-S3, DL-m1, DL-m3, have a built in computer to allows one touch adjustment using the 0 adjust and 1/2 adjust buttons

Zero point set

Levelnic does not have true horizontal reference built in. When it is turned on, the first number that appears is not necessarily referenced to true horizontal. If you need to reference true horizontal, you will have to set a zero point each time you turn it on. Once the zero point is correctly set, each measurement is properly reference to true horizontal, eliminating any possible errors from the deviation of zero point. To set zero point a "0 adjust" and "1/2 adjust" operation must be performed.

A) To compare slope of different surfaces

- ① Place levelnic on an inclined surface.
 - ② When display stabilizes press "0 adjust" and "0" will be displayed.
- For comparison purposes a zero point has been set which is not true horizontal.

B) If zero point is set to true horizontal.

- ① Place the levelnic on the surface to be adjusted to horizontal
 - ② Adjust surface until display stabilizes to zero
- The surface is level

C) If you are unsure if a surface is horizontal

- ① Place the levelnic on the surface
 - ② When display stabilizes press "0 adjust" and "0" will be displayed
 - ③ Rotate the levelnic 180° and put in the same spot
 - ④ When display stabilizes press "1/2 adjust", and display will be halved.
- Zero is now set to true horizontal

To set the zero point precisely, there should be minimal slope in the roll direction (perpendicular to the measurement axis) so please set the level in two directions (X, Y) to set zero.

Handling instruction for Levelnic

- Levelnic is a precision instrument. Please handle with care and avoid shock such as bumping or dropping.
- Before use, the levelnic base and the surface to be measured should be wiped clean of any dirt or oil using a paper towel or cloth dampened with ligroin or alcohol.
- There should be no temperature difference between levelnic and surface being measured. In general, precision measurements should be done in a temperature controlled environment.
- After use, the levelnic base should be coated with an anti-rust oil to protect from corrosion.

LEVELNIC DL-S3

High accuracy Level with Simple & Clear Operation
 Worlds first Digital Level with built-in Microcomputer

■ Digital Display
 0.001mm/m



- MATERIALS
- Body : Aluminum
 - Base : Cast Iron

- FEATURES
- Easy to Fix the Datum point, Divide measurement value into halves with one-touch operation (With "0" cal. switch, 1/2 cal. switch)
 - Measurement value can be output with RS232 signal
 - Connectible to PC or Printer with RS232 interface
 - Custom-made base can be attached to the threaded screw holes in the bottom base

■ SPECIFICATIONS

Measuring Range	± 5.00mm/m · ± 0.286°	
Minimum Reading	± 0.001mm/m · ± 0.0001° (0 ~ ± 2mm/m · 0 ~ ± 0.115°) ± 0.01mm/m · ± 0.001°	
Operating Temperature	0 ~ 40°C	
Accuracy	17 ~ 23°C	± 0.85%rdg (0 ~ ± 2mm/m · 0 ~ ± 0.115°) ± 1.0%rdg (± 2 ~ ± 5mm/m · ± 0.115° ~ ± 0.286°)
	0 ~ 40°C	± 2.6%rdg (0 ~ ± 2mm/m · 0 ~ ± 0.115°) ± 2.7%rdg (± 2 ~ ± 5mm/m · ± 0.115° ~ ± 0.286°)
Repeatability	Within ± 0.005mm/m · ± 0.0003°	
Output Signal	Conforms to RS-232C	
Dimensions	L172 × W65 × H129mm (Base Dimension : L150 × W55mm)	

※ 1 : For DEG (°) Display mode, "0 (Zero)" before the decimal point is not displayed.
 For 0.001mm/m (0.0001°) display mode, maximum reading which can be displayed is less than ± 1.999mm/m (± 0.1145°)
 ※ 2 : % rdg indicates the percentage of displayed value

Model No.	DL-S3	DL-S3C
Charging time	—	12hours (when fully charged)
Power Source	"9V" type dry cell, 1 pc AC adapter	Ni-MH rechargeable 8.4 nominal voltage, 200mAh
Run time (continuous use) ※3	Zinc-carbon Cell : approx. 10 hrs. Alkaline Cell : approx. 20 hrs.	12hour charge... approx. 9hrs 8hour charge... approx. 6hrs 4hour charge... approx. 2hrs

※ 3 : May vary depending upon measurement conditions

Order No.	Model No.	Weight
010013	DL-S3	2.2kg
010030	DL-S3C	2.2kg

■ With V Groove (available on request)

Model	DL - S3V
Tolerance	Within 0.1mm/m (On condition that the bubble in the sub-bubble tube is within the base line)
Tolerance between Flat and V Groove	Within 0.05mm/m
Angle of V Groove	130° (for cylindrical objects up to φ 65mm)



LEVELNIC DL-S3 with magnetic L-type base.
Magnetic base enables Z-axis measurement in addition to X-axis and Y-axis.



- USE**
 - High precision leveling of machine tools and surface plates, Straightness, flatness, and vertical measurement
- MATERIALS**
 - DL-S3 / Body: Aluminum, Base: Cast Iron
 - L-type base : Cast Iron
- FEATURES**
 - Quick display of the measured value
 - Measurement value can be output with RS-232 signal.
 - L-type magnetic base enables vertical(Z-axis) measurement
 - With 130° V groove

Order No.	Model No.	Base Squareness (mm)	Weight
010027	DL-S3L	within ± 0.04	5.5kg

※ Refer to DL-S3 for detailed specifications for this unit.

L-TYPE BASE

LEVELNIC DL-S3 or DL-S2W, equipped with L-type base enables measurement in the Z-axis in addition to X-axis and Y-axis



DIMENSIONS

Units : mm

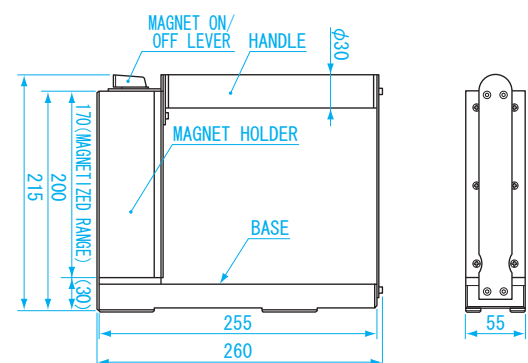

- MATERIALS**
 - Cast Iron
- FEATURES**
 - Applicable Levelnic: DL-S3 · DL-S2W
 - Vertical(Z-axis) measurement is available by mounting on Levelnic
 - With 130° V groove

Order No.	Model No.	Base Squareness (mm)	Weight
010028	DL-SL	within ± 0.04	4.9kg

ANGLE

LEVELNIC

PRECISION LEVEL

ANGLE LEVEL

LEVEL

PROTRACTOR



TRANSMITTER / DISPLAY SET

Connects to two DL-S3 at the same time
Receiver can display measurements from X and Y directions

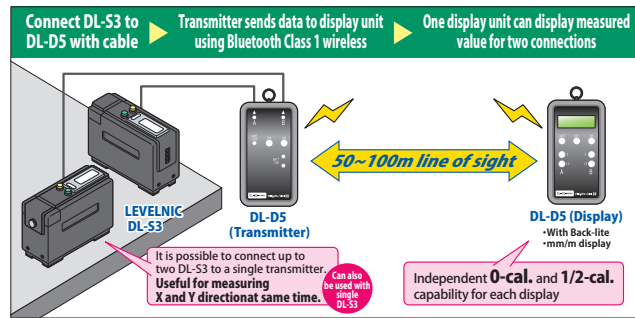

USE • Transmit and display measurements for up to two Levelnic DL-S3

FEATURES

- Simultaneous display of two connected DL-S3. Useful for measuring X and Y directions.
- Eases installation of large machine tools by allowing multiple operators to work at same time
- Measured data is more easily visible, especially when used in locations which are remote or have low clearance height.
- Since transmitter and receiver are a paired set, there is no need to set up after purchase – it can be used immediately.

Order No.	Model No.	Compatible Model	Weight
010043	DL-D5	DL-S3 · DL-S3C	290g each ※

※ Including silicone battery cover

SPECIFICATIONS

	Transmitter	Display
Input	Levelnic DL-S3 external signal (x2)	—
Display	—	16char × 2lines, character size = 4.9 × 2.5mm, with backlight
Wireless	Bluetooth Class1	
Communication range	50 ~ 100m line-of-sight (depending on conditions)	
operating temperature	0 ~ 40°C	
Power	2x AA cells (can also use commercially available rechargeable batteries)	
operating life (continuous use)	communicating with display device : approx. 17 hours attempting communication with display : approx: 3 hours	Alkaline cells : approx. 8 hours
DIMENSIONS	144 × W76 × D27mm (Including lanyard ring) (when mounted in silicone cover : L147 × W81 × D35mm)	
Accessories	2x connecting cable (approx. 80cm length) 2x AA cells, Silicone cover.	2x AA cells, Silicone cover

LEVELNIC WIRELESS ADAPTER DL-BW

Allows communicating with Levelnic using Bluetooth
Wireless range of 50-100mm line-of-sight

USE • Wireless adapter for Levelnic

MATERIALS • Body: Stainless

- FEATURES**
- The RS232C output signal is transmitted using Bluetooth wireless
 - Eliminating cables greatly improves work efficiency



Shown mounted on DL-S3C

Order No.	Model No.	Weight
010038	DL-BW	530g

SPECIFICATIONS

Input	Levelnic RS-232C signals (Levelnic use only)
Wireless System	Bluetooth Class1
Power Source	AAA battery 6 pcs (rechargeable batteries can be used)
Run time (continuous use)	Alkaline cell : Approx. 70 hrs/ Zinc-carbon cell : Approx. 30 hrs 1700mAh rechargeable battery: Approx. 45 hrs ※ May vary depending upon measurement conditions
Dimensions	L143 × W50 × H173mm (Including transmission unit)
Applicable Levelnic	DL-S3, DL-S3C, DL-m3, DL-m3LS, DL-D3, DL-S3L ※ DL-S3, DL-S3C can direct mount

※ A small thermal printer can not be used



■ High accuracy Digital Level
(Wireless by Bluetooth)
Resolution 0.001mm/m

Wireless Data transmission.
The maximum longitudinal coverage is
50~100m.



- MATERIALS
 - Body: Aluminum
 - Base: Cast iron
- FEATURES
 - Wireless type Levelnic, useful for leveling and tilt measurement;
 - In overhead location
 - In places where the cable can not reach
 - PC screen becomes Display of Levelnic
 - Measurement data can be displayed on PC, using receiver and Data display software
 - Wireless data transmission
 - Custom-made base can be attached to the threaded screw holes (M5 × P0.8) in the bottom of Level base (Flat base)

■ SPECIFICATIONS

Measuring Range	± 5.000mm/m · ± 0.2865°
Minimum Reading	0.001mm/m · 0.0001°
Operating Temperature	0 ~ 40°C
Accuracy	17 ~ 23°C ± 0.85% rdg (0 ~ ± 2mm/m, 0 ~ ± 0.1146°)
	± 1.0% rdg (± 2 ~ ± 5mm/m, ± 0.1146 ~ ± 0.2865°)
	0 ~ 40°C ± 2.6% rdg (0 ~ ± 2mm/m, 0 ~ ± 0.1146°)
	± 2.7% rdg (± 2 ~ ± 5mm/m, ± 0.1146 ~ ± 0.2865°)
Repeatability	within ± 0.005mm/m · ± 0.0003°
Radio System	Bluetooth Class1
Power Source	"9V" type dry cell (1pc)
	AC Adapter (AC 100V) included
Run time (Continuous use)	Alkaline dry cell: Approx. 10 hrs
	※ May vary depending upon measurement conditions
Dimensions	L173 × W59 × H147mm (H : up to top of Antenna)
	(Base Dimensions : L150 × W55mm)

※ % rdg indicates percentage of displayed value

Order No.	Model No.	Weight
010017	DL-S2W	2.1kg

ANGLE

LEVELNIC

PRECISION LEVEL

ANGLE LEVEL

LEVEL

PROTRACTOR



LEVELNIC DATA SYSTEM

Enables data display and saving of up to 8 levelnic with one PC

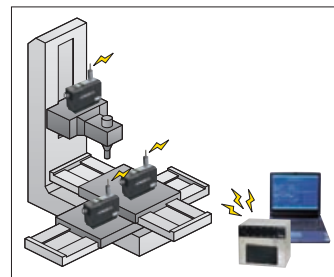

Example using multiple units with Bluetooth wireless communication

- USE** • For data management of multiple Levelnics
- MATERIALS** • Body: Stainless steel
- FEATURES** • 8 Levelnics can be connected at once
 - Data display software included
- SPECIFICATIONS**

Order No.	Model No.	Weight
010037	DL-ADP	1.6kg

Input	D-SUB (9 pins, male) RS-232C compliant, 8 inputs (For Levelnic connection only) 1200 Baud, 1 stop bit, No parity, No handshaking
Output	D-SUB (9 pins, male) RS-232C compliant, 1 output (PC connection) 9600 Baud, 1 stop bit, No parity No Hardware handshaking
Operating Temperature	0 ~ 40°C
Power Source	AC100V Adapter [DC9V Output] (Included) AAA batteries (1.5V) 6 pc ※ Run time depends on number of Levelnics
Dimensions	W180 × H150 × D130mm
Applicable Levelnic	DL-S3, DL-S3C, DL-S3L, DL-m3, DL-m3LS, DL-S2W ※ DL-P5AD, DL-P6 can also use cable connection ※ DL-S2W, DL-BW can connect using built-in wireless capability

LEVELNIC DISPLAY

Can display data at a distance of 50-100m (line-of-sight). Enables measurement process to be done by one person. The work of two can be done by one person.



Combination example with DL-S2W

- USE** • Levelnic measurement data display
- MATERIALS** • Body: Stainless steel
- FEATURES** • Can divide measurement value into half with one-touch operation (DL-S2W only)
- SPECIFICATIONS**

Order No.	Model No.	Weight
010024	DL-D4	330g

Display Range	As per Levelnic spec.
Minimum Reading	As per Levelnic spec.
Operating Temperature	0 ~ 40°C
Input Signal	Conforms to RS-232C (Levelnic digital output signal only)
Power Source	" 9V" type dry cell / AC adapter (included)
Run time (Continuous use)	with wireless connection : Alkaline cell : Approx. 5 hrs with cable connection : Alkaline cell : Approx. 60 hrs ※ May vary depending upon measurement conditions
Dimensions	L116 × W62 × H48mm
Applicable Levelnic	DL-S3, DL-S3C, DL-S3L, DL-m3, DL-m3LS, DL-S2W ※ DL-P5AD, DL-P6 can also use cable connection ※ Can connect to Wireless such as DL-S2W, DL-BW

LEVELNIC DL-m1



ANGLE

Digital display with 0.01mm/m resolution. Unlike bubble level, there is no delay waiting for reading to settle, reducing human error.

High accuracy Level Digital Display 0.01mm/m



- USE**
 - High precision leveling of machine tools and surface plates. Straightness and flatness measurement.
- MATERIALS**
 - Body: Aluminum
 - Base: Cast iron
- FEATURES**
 - Compact, Lightweight and simple operation
 - Easy to fix the Datum point, divide measurement value into half with one touch operation
 - Fast output reduces installation time for field work

Order No.	Model No.	Weight
010014	DL-m1	880g

SPECIFICATIONS

Measuring Range	± 5.00mm/m
Minimum Reading	0.01mm/m
Operating Temperature	0 ~ 40°C
Accuracy ※	17~23°C ±0.02mm/m or ±3% rdg whichever is larger (0~±2mm/m) ±4% rdg (±2~±5mm/m) 0~40°C ±0.02mm/m or ±5% rdg whichever is larger (0~±2mm/m) ±6% rdg (±2~±5mm/m)
Repeatability	within ± 0.01mm/m
Power Source	9V type dry cell, 1 pc
Run time (continuous use)	Zinc-carbon cell Approx. 45 hrs, Alkaline cell Approx. 90 hrs. ※ May vary depending upon the measurement conditions
Dimensions	L105 × W50 × H73mm (Base Dimensions : L100 × W50mm)

※ % rdg indicates the percentage of displayed value

07

LEVELNIC DL-m3



High accuracy digital level 0.01mm/m, with RC-232C



- USE**
 - High precision leveling of machine tools and surface plates. Straightness and flatness measurement.
- MATERIALS**
 - Body: Aluminum
 - Base: Cast iron
- FEATURES**
 - Equipped with RS-232C output and Softwares for Data Saving, and calculating Flatness, Straightness
 - Easy to fix the Datum point, divide measurement value into half with one touch operation
 - Digital display for easy to read measurement
 - Compact, Light weight and Simple operation

Order No.	Model No.	Weight
010015	DL-m3	880g

SPECIFICATIONS

Measuring Range	± 5.00mm/m
Minimum Reading	0.01mm/m
Operating Temperature	0 ~ 40°C
Accuracy ※	17~23°C ±0.02mm/m or ±3% rdg whichever is larger (0~±2mm/m) ±4% rdg (±2~±5mm/m) 0~40°C ±0.02mm/m or ±5% rdg whichever is larger (0~±2mm/m) ±6% rdg (±2~±5mm/m)
Repeatability	within ± 0.01mm/m
Output Signal	Conforms to RS-232C
Power Source	" 9V" type dry cell, 1 pc
Run time (continuous use)	Zinc-carbon cell Approx. 35 hrs, Alkaline cell Approx. 70 hrs. ※ May vary depending upon measurement conditions
Dimensions	L105 × W50 × H73mm (Base Dimensions : L100 × W50mm)

※ % rdg indicates percentage of displayed value

ANGLE

LEVELNIC

PRECISION
LEVEL

ANGLE
LEVEL

LEVEL

PROTRA
CTOR



LEVELNIC DL-m3LS

Levelnic DL-m3 on L-type Base
X axis·Y axis and in addition, Z-axis measurements are possible



USE • High precision leveling of machine tools and surface plates. Straightness, flatness and vertical measurement.

MATERIALS • DL-m3 Body: Aluminum, Base: Cast iron
• L type base: Cast iron

FEATURES • Digital Display
• Small and lightweight
• Equipped with RS-232C output and software for data saving, and calculating flatness, straightness
• L type base allows measurements in the vertical direction
• with 130° V groove

※ Base does not have magnetic capability

Order No.	Model No.	Base Squareness (mm)	Weight
010019	DL-m3LS	within ± 0.035	2.8kg

※ DL-m3LS conforms to DL-S3 specifications

L-TYPE BASE FOR LEVELNIC DL-mL

Levelnic DL-m1, m3 mounted on base will be able to take vertical measurements



DIMENSIONS

Units : mm

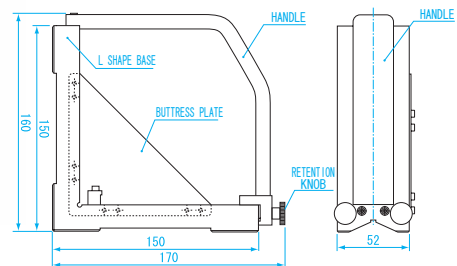

※ Base does not have magnetic capability

MATERIALS • Cast iron

FEATURES • Applicable Levelnic : DL-m1 · DL-m3
• Levelnic DL-m1, m3 mounted on base will be able to take vertical measurements
• with 130° V groove

Order No.	Model No.	Base Squareness (mm)	Weight
010022	DL-mL	within ± 0.035	1.9kg

High accuracy digital Level with output to external display 0.001mm/m



- Digital sensor (DL-S2) • Digital display (DL-D3) • Cable (DL-P1) as combined system.
- ※ **PC is not included**

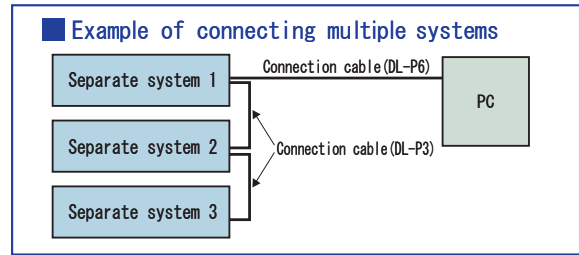

USE

- High precision leveling of machine tools and surface plates. Straightness and flatness measurement for digital display

MATERIALS

- Body: Aluminum • Sensor base : Cast iron

FEATURES

- Display allows machine tool data obtained by Levelnic to be close at hand.
- When leveling large equipment or in high places, the separate display allows the operator to easily see the data.
- Output data is available on built in RS-232C interface for connection to computer or printer
- Multiple output signals can be combined onto one signal allowing expansion to 2, 3, or 4 devices for easy processing
- Easy to fix the Datum point, divide measurement value into half with one touch operation
- Custom-made base can be attached to the threaded screw holes (M5 × P0.8) in the bottom of digital sensor base

SPECIFICATIONS

Measuring Range	± 5.000mm/m • ± 0.2865°
Minimum Reading	0.001mm/m • 0.0001° 0.01mm/m • 0.001°
Operating Temperature	0 ~ 40°C
Accuracy	17 ~ 23°C ± 0.85% rdg (0 ~ ± 2mm/m • 0 ~ ± 0.1146°) ± 1.0% rdg (± 2 ~ ± 5mm/m • ± 0.1146 ~ ± 0.2865°) 0 ~ 40°C ± 2.6% rdg (0 ~ ± 2mm/m • 0 ~ ± 0.1146°) ± 2.7% rdg (± 2 ~ ± 5mm/m • ± 0.1146 ~ ± 0.2865°)
Repeatability	within ± 0.005mm/m • ± 0.0003°
Output Signal	Conforms to RS-232C
Power Source	AAA battery 6 pc AC adapter (included)
Run time (Continuous use)	Zinc-carbon cell : Approx. 27 hrs Alkaline cell : Approx. 55 hrs ※ May vary depending upon measurement conditions
Dimensions	DL-S2 L167 × W59 × H111mm (Base Dimension : L150 × W55mm) DL-D3 L235 × W106 × H51mm DL-P1 Length : 5m (standard cable)

Order No.	Model No.	Weight
010023	DL-D3	1kg
010012	DL-S2	2kg
010031	DL-P1	400g
010033	DL-P3	100g

PC connection cable

USE

- For connecting Levelnic to PC, printer (DL-P6 not for printer connection)

FEATURES

- Length: φ 3 × 5m
- DL-P5AD : 25-pin connector, with pin adapter 25 → 9 (serial port connection)
- DL-P6 : 9 pins connector (Serial port connection)
- Applicable Levelnic : DL-m3 • DL-S3 • DL-m3L • DL-S3L • DL-S3C • Separate system

Order No.	Model No.	Material
010036	DL-P5AD	2 cond. w/ shield (Cu)
010040	DL-P6	2 cond. w/ shield (Cu)

LEVELNIC DL-S1

Digital display with 0.01mm/m resolution. Unlike bubble level, there is no delay waiting for reading to settle, reducing human error.

- Digital display with 0.01mm/m resolution



- **USE**
 - High precision leveling of machine tools and surface plates, Straightness and flatness measurement
- **MATERIALS**
 - Body : Aluminum
 - Base : Cast iron
- **FEATURES**
 - Faster response than bubble level
 - Wider range of measurement than conventional level
 - Measurement can be taken in difficult to see position by pressing hold switch and then reading

■ SPECIFICATIONS

Measuring Range	± 9.99mm/m
Minimum Reading	0.01mm/m
Operating Temperature	0 ~ 40°C
Accuracy	17 ~ 23°C ± 1.3% rdg 0 ~ 40°C ± 3.0% rdg
Repeatability	within ± 0.01mm/m
Power Source	"9V" type dry cell × 1 AC adapter (Optional)
Run time (continuous use)	Zinc-carbon Cell---Approx. 25 hrs Alkaline Cell---Approx. 50 hrs ※ May vary depending upon measurement conditions
Dimensions	L159 × W78 × H104mm (Base Dimension : L150 × W55mm)

※ 1 : AC adapter sold separately
 ※ 2 : % rdg indicates percentage of displayed value.

Order No.	Model No.	Weight
010011	DL-S1	2.0kg

- Also available with special V-groove base

Model	DL - S1V
Rolling Error	Within 0.1mm/m
Plane and V groove error	0.05mm/m
V groove angle	130° (for cylindrical objects up to φ 65mm)

**High-sensitive (0.01mm/m) Pendulum type level with analog output.
Three levels of sensitivity**

**■ Analog Display
0.01mm/m**

■ USE • Leveling of machine tools and surface plates. Straightness and flatness measurements.

■ MATERILAS • Body : Aluminum
• Base : Cast iron

- FEATURES**
- Quicker response than bubble level
 - Sensitivity is switchable in 3 steps
 - Connectible directly to commonly-available analog recorder through analog output
 - Custom-made base can be attached to the threaded screw holes (M5 × P0.8) in the bottom of level base(flat base)
 - Automatically switches from DC to AC when the adapter is connected
 - Pendulum system prevents any hysteresis errors and is not influenced by temperature change.



■ SPECIFICATIONS

Sensitivity	I : 1 Division = 0.01mm/m II : 1 Division = 0.05mm/m III : 1 Division = 0.1mm/m
Measuring Range	± 0.2mm/m (1 Division 0.01mm/m) ± 1mm/m (1 Division 0.05mm/m) ± 2mm/m (1 Division 0.1mm/m)
Operating Temperature	0 ~ 40°C
Pointing Error	within ± 0.5 Division
Repeatability Accuracy	within ± 0.005mm/m
Output Signal	Analog output ± 200mV F.S. (for all range) Connectible load resistance: No less than 100 Ω
Power Source	"9V" type dry cell, 1 pc AC Adapter (included)
Run time (continuous use)	Zinc-carbon Cell : Approx. 25 hrs Alkaline cell : Approx. 50hrs ※ May vary depending upon measurement condition
Base Dimension	L150 × W85 × H195mm ※ Excluding Handle (Dimension : L150 × W55mm)

Oeder No.	Model No.	Weight
010005	EL-01A	2.9kg

Connection Cable / EL-K2

■ USE • Connects to analog recorder with analog output of EL-01A

- FEATURES**
- Length : φ 3 × 5m
 - Recorder: Banana plug
 - Levelnic : M3 plug

Oeder No.	Model No.	Weight
010082	EL-K2	150g



SOFTWARE FOR LEVELNIC

Software for Levelnic.
Simple operation and graphics for easy use and understanding

Straightness measurement computer software (ST)
Flatness measurement computer software (FL)

- Greatly reduces measurement time by recording the results for straightness and flatness measurements
- For cabled and wireless system
- Supported OS : Windows 95 • 98 • ME • 2000 • XP • Vista • 7
- Direct input from DL-S2+D3, DL-S3, DL-S3C, DL-S3L, DL-m3, DL-m3LS, DL-S2W, and Separate System

■ Flatness measurement



■ Straightness measurement while connected to PC

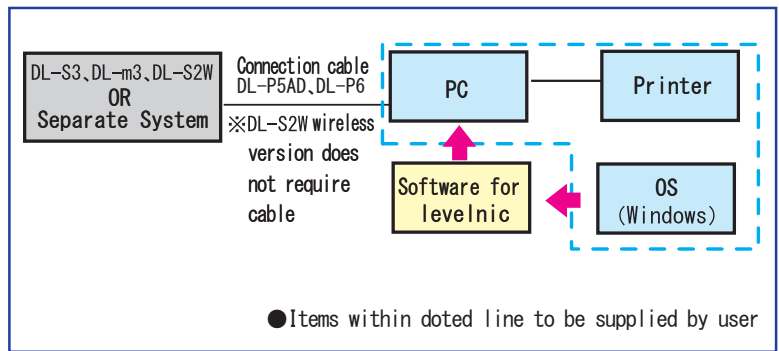
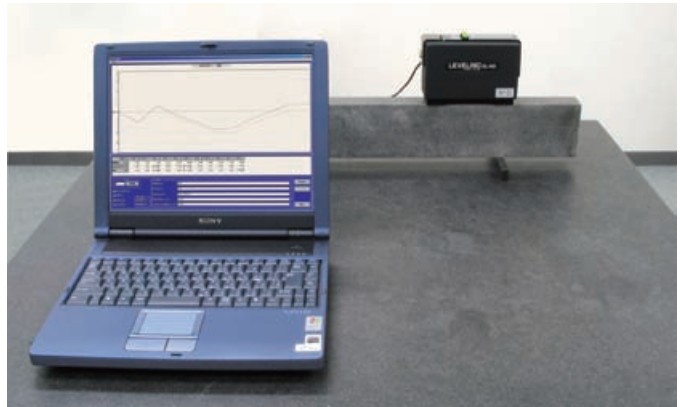

No need to install the software to PC

Only drag and drop .exe file, and double click to start. Also can be used directly from USB memory.

Input selection

Data can be manually typed in from any level, including bubble tube type level.

Input signal from Levelnic over RS-232C

With computer connected to the Levelnic output, sequential measurements taken at regular intervals can be used to calculate flatness and straightness for display, printing and storage. (saved measurement data can not be revised)

Input typed onto keyboard from bubble level for display, calculation and storage

Using a bubble level, and keyboard to enter data, sequential measurement taken at regular intervals can be used for calculation, display and storage.

Displacement measurements (µm) typed onto keyboard for display, calculation and storage

Measurement of displacement from a reference plane made with a linear gauge or dial indicator at regular intervals can be used in place of an electronic angle gauge (goniometer) and entered into keyboard for calculation, display and storage.

LEVELNIC MEASUREMENT SOFTWARE

Use to easily calculate flatness and straightness when connected to Levelnic with cable or wireless connection

Straightness software ver. 2.0

● With straightness software Levelnic can easily perform the straightness measurements that once required an autocollimator, and for a lower cost!

■ Straightness measurement

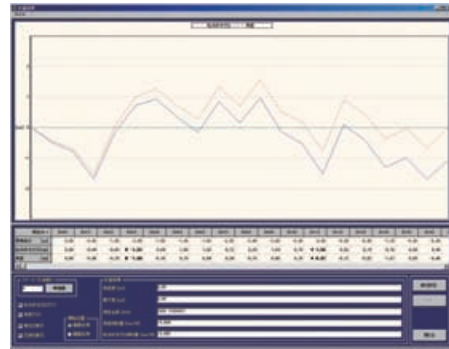
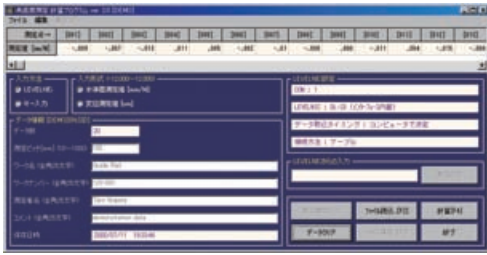

■ **USE** • Software to perform straightness calculations

FEATURES

- Both wired and wireless capability
- Model compatibility: DL-S2 + D3 • DL-S3 • DL-S3C • DL-S3L • DL-m3 • DL-m3LS • DL-S2W
 ※ Above compatibility applies for direct connection. Data can be manually typed in from any model, including bubble tube type level.

SPECIFICATIONS

- Supports : Windows 95 • 98 • ME • 2000 • XP • Vista • 7

Order No.	Model No.
010066	ST

Flatness software Ver. 2.0

● With Flatness software Levelnic can easily perform the flatness measurements that once required an autocollimator, and for a lower cost!

■ Flatness measurement

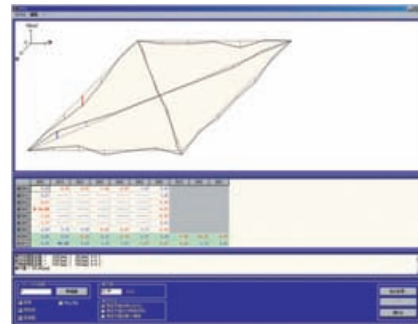

■ **USE** • Software to perform flatness calculations

FEATURES

- Both wired and wireless capability
- Model compatibility: DL-S2 + D3 • DL-S3 • DL-S3C • DL-S3L • DL-m3 • DL-m3LS • DL-S2W
 ※ Above compatibility applies for direct connection. Data can be manually typed in from any model, including bubble tube type level.

SPECIFICATIONS

- Supports : Windows 95 • 98 • ME • 2000 • XP • Vista • 7

Order No.	Model No.
010065	FL

Data Record Software Ver. 2.0

■ **USE** • Records output data from Levelnic

FEATURES

- Levelnic measurements are recorded to text file
- Model compatibility: DL-S2 + D3 • DL-S3 • DL-S3C • DL-S3L • DL-m3 • DL-m3LS • DL-S2W

SPECIFICATIONS

- Supports : Windows 95 • 98 • ME • 2000 • XP • Vista • 7

Order No.	Model No.
010067	LEVELOG



LEVELNIC BASE WITH ADJUSTABLE PITCH

By attaching Levelnic to this base, any desired measurement pitch can be set



LP-300

DIMENSIONS

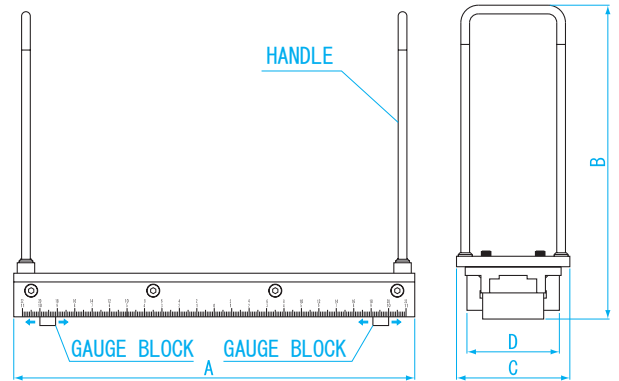

USE • Setting a fixed pitch for straightness and flatness measurements

FEATURES

- Made of Carbon tool steel
- Applicable levelnic: DL-S2 • DL-S3 • DL-S3C • DL-S2W • EL-01A
- The base is graduated in mm and enables setting measurement pitch
- Measuring face consists of 2 pcs of 15mm Gauge block

Units : mm

Model No.	A	B	C	D
LP-200	230	180	65	55
LP-300	330	180	65	55

Order No.	Model No.	Measurement pitch range (mm)	Weight
010020	LP-200	50 ~ 200	1.8kg
010021	LP-300	50 ~ 300	2kg

CASE FOR LEVELNIC



Shock resistant aluminum case for Levelnic. Suitable for storage and carrying



LV-CS3



LV-CM1

FEATURES

- Carrying case for Levelnic (Levelnic is a precision instrument, we recommend that you use a carrying case)
- Body : Aluminum
- Inside : Urethane foam
- Applicable levelnic :
LV-CS3 : DL-S1 • DL-S2 • DL-S2W • DL-S3 • DL-S3C
LV-CM1 : DL-m1 • DL-m3
- Shock protection during transport

Order No.	Model No.	Dimensions (mm)	Weight
010025	LV-CS3	362 × 236 × 184	1.86kg
010026	LV-CM1	250 × 200 × 150	1.15kg

PRECISION LEVEL (JIS CLASS A)



- USE**
- Bubble tube indicates horizontal and measures small inclinations
 - Precision measurement for machine inspection and leveling

FEATURES

- JIS B7510 standard product
- Special tool steel body (hardened) is lapped and polished
- Sensitivity : 0.02mm/m
- Accuracy of the main bubble Full range accuracy : less than ± 0.5 graduation
Adjacent accuracy : less than 0.2 graduation
- Parallelism between V groove and base : within 0.5 graduation
- Parallelism on base : within 0.003mm

Order No.	Model No.	Standard (mm)	Dimensions L × W × H (mm)	Weight
160001	FLA-150002	150	150 × 44 × 42	1.6kg
160002	FLA-200002	200	200 × 46 × 42	2.3kg
160003	FLA-250002	250	250 × 46 × 42	2.5kg
160004	FLA-300002	300	300 × 46 × 42	3.2kg

PRECISION LEVEL



- USE**
- Bubble tube indicates horizontal and measures small inclinations
 - For machine installation and general mechanical assembly

FEATURES

- Quality cast iron(FC250) with perfect seasoning and lapped to a fine finish to maintain precision
- Sensitivity : 0.02mm/m

Order No.	Model No.	Standard (mm)	Dimensions L × W × H (mm)	Weight
160005	FLW-150002	150	150 × 44 × 42	1.6kg
160006	FLW-200002	200	200 × 46 × 42	2.3kg
160007	FLW-250002	250	250 × 46 × 42	2.5kg
160008	FLW-300002	300	300 × 46 × 42	3.2kg



SQUARE PRECISION LEVEL (JIS CLASS A)



- USE**
 - Bubble tube indicates horizontal and measures small inclination
 - Precision measurement for machine inspection and leveling

FEATURES

- JIS B7510 standard product
- Special tool steel body (hardened) is lapped and polished
- Sensitivity : 0.02mm/m
- Accuracy of the main bubble
 - Full range of the main bubble : less than ± 0.5 graduation
 - Adjacent accuracy : less than 0.2 graduation
- Perpendicularity of sides and bottom : less than 0.015mm/m
- Parallelism of V groove and V groove surface : less than 0.5 graduation
- Parallelism of top and bottom : less than 0.5 graduation
- Flatness of bottom and sides : less than 0.003mm

Order No.	Model No.	Standard (mm)	Dimensions L x W x H (mm)	Weight
160009	SLA-150002	150	150 x 40 x 150	2.8kg
160010	SLA-200002	200	200 x 43 x 200	4.6kg
160011	SLA-250002	250	250 x 45 x 250	7.2kg
160012	SLA-300002	300	300 x 47 x 300	8.8kg

GENERAL PURPOSE SQUARE PRECISION LEVEL



- USE**
 - Bubble tube indicates horizontal and measures small inclinations
 - Ideal for machine assembly and general purpose use

FEATURES

- Quality cast iron (FC250) with perfect seasoning and lapped to a fine finish to maintain precision
- Sensitivity : 0.02mm/m

Order No.	Model No.	Standard (mm)	Dimensions L x W x H (mm)	Weight
160013	SLW-150002	150	150 x 40 x 150	2.8kg
160014	SLW-200002	200	200 x 43 x 200	4.6kg
160015	SLW-250002	250	250 x 45 x 250	7.2kg
160016	SLW-300002	300	300 x 47 x 300	8.8kg

DIGITAL PROTRACTOR DP-50



ANGLE

Digital angle measurement. High precision measurement & quick measurement time

- USE**
 - For angle of tilt measurement
- MATERIALS**
 - Body : Aluminum
- FEATURES**
 - Digital angle meter is useful tool for every site
 - Slit encoder ensures accuracy and stability
 - Zero setting not required
 - Zero setting function
 - Display hold function
 - Measuring face : V-Groove (2 sides)
 - Vertical sides are magnetic
 - Display unit : DEG



SPECIFICATIONS

Measuring Range	± 50°
Minimum Reading	0.1°
Accuracy	± 0.1° (0 ~ 50°)
Repeatability	± 0.1°
Operating Temperature	0 ~ 50°C
Display Units	DEG
Dimensions	L141 × W47 × H109mm (excluding protrusions)
M5 Mounting holes	Screw hole spacing- 80mm (distance from end to screw hole -11mm)
Power Source	"9V" type dry cell, 1 pc
Run time (continuous use)	Alkaline dry cell : Approx. 15 hrs ※ May vary depending upon measurement conditions
Accessories	Soft case, Manual, 9V battery

Order No.	Model No.	Weight
010091	DP-50	950g

DIGITAL PROTRACTOR DP-90



Digital angle measurement. High precision measurement & quick measurement time

- USE**
 - Angle of tilt measurement
- MATERIALS**
 - Body: Aluminum
- FEATURES**
 - Wide range of measurement (90°)
 - Automatically reverses display when turned upside down
 - Display options : DEG, mm/m, % slope
 - Notification tones for 0°, 90° and for 0%, 0mm/m
 - Display hold function
 - Measuring surface : V-Groove, with magnet
 - Auto power off function (after 6 min)



SPECIFICATIONS

Measuring Range	± 90°
Minimum Reading	Degree display : 0.05°
	Percent display : 0.1%
	Gradient : 1mm/m
Accuracy	0.0° ~ 90.0° = ± 0.2°
Operating Temperature	0 ~ 50°C
Display Setting Time	Approx. 10 sec
Power Source	"9V" type dry cell, 1 pc
Dimensions	L173 × W47 × H68mm (excluding protrusions)
Accessories	Soft case, Manual, 9V dry cell

Order No.	Model No.	Weight
010092	DP-90	550g

07

ANGLE

LEVELNIC

PRECISION
LEVEL

ANGLE
LEVEL

LEVEL

PROTRA
CTOR



DIGITAL ANGLE GAUGE DP-10XY

New product! This two-axis digital inclinometer takes measurements in X and Y direction at same time With 0 cal., 1/2 cal. features, can also be used as a level



Output from sensors can also be displayed or recorded on PC with dedicated software.

USE • Surface plate and machine tool angle of inclination measurement

MATERIAL

- Case: Aluminum
- Base: Aluminum alloy

FEATURES

- Simultaneously measures angle of inclination in X and Y directions making leveling tasks easier
- Display is switchable to show only X, only Y, or XY measurements
- 0-cal. and 1/2 cal. switches allow calibration at the touch of a button.
- In sensor mode, the measurement range is $\pm 9.99^\circ$ with minimum reading of 0.002° (0-cal. and 1/2 cal. can not be used in this mode)
- Built in output for display of sensor reading on PC
- Back-light display
- Output from sensors can also be displayed or recorded on PC with dedicated software.

SPECIFICATIONS

Measuring range	$\pm 9.99^\circ$
Minimum reading	0.01°
Operating temperature	$0 \sim 40^\circ\text{C}$
Accuracy	$\pm 0.01^\circ$ (for measuring range less than $\pm 2^\circ$) $\pm 0.05^\circ$ (for measuring range greater than $\pm 2^\circ$)
Repeatability	$\pm 0.01^\circ$
XY orthogonal accuracy	1%
Response time (measurement period)	approx. 2.5s
Output signal	Conforms to RS-232C
Power	2x AA cells AC Adapter (3V)
Run time (continuous use)	Alkaline cells approx. 10 hrs. ※ may vary depending on measurement conditions
Dimensions	L88 × W85 × H73mm

Order No.	Model No.	Weight
NEW 010093	DP-10XY	560g



New Products! Wireless 2-axis digital angle gauge with remote display set. Capable of simultaneous X and Y measurements.

Model	Sensor:DP-10S Display:DP-10D
Measuring range	± 9.99°
Minimum reading	0.01°
Operating temperature	0 ~ 40°C
Accuracy	± 0.01° (for measuring range less than ± 2°) ± 0.05° (for measuring range greater than ± 2°)
Wireless	Bluetooth Class 1
Communication range	30 ~ 50m
Repeatability	± 0.01°
XY orthogonal accuracy	1%
response time (measurement period)	approx. 2.5s
Output signal	Conforms to RS-232C (DP-10D)
Power	2x AA cells each / AC Adapter (3V)
Run time (continuous use)	DP-10S: approx. 10 hrs. (communicating) approx 4 hrs. (waiting to communicate)
Alkaline cells	DP-10D : About 10 hrs.
Dimensions	DP-10S : L85 × W85 × H73mm DP-10D : L145 × W76 × H30mm
Weight	DP-10S : 540g
(Including battery)	DP-10D : 230g



- USE** • Surface plate and machine tool angle of inclination measurement
- MATERIAL**
 - DP-10S...Case:Aluminum / Base: Aluminum alloy
 - DP-10D...Case: ABS
- FEATURES**
 - Simultaneously measures angle of inclination in X and Y directions making leveling tasks easier
 - Display is switchable to show only X, only Y, or XY measurements
 - 0-cal. and 1/2 cal. switches allow calibration at the touch of a button.
 - In sensor mode, the measurement range is ± 9.998° with minimum reading of 0.002° (0-cal. and 1/2 cal. can not be used in this mode)0-cal. and 1/2 cal. switches allow calibration at the touch of a button.
 - In sensor mode, the measurement range is ± 9.998° with minimum reading of 0.002° (0-cal. and 1/2 cal. can not be used in this mode)
 - Built in output for display of sensor reading on PC
 - Output from sensors can also be displayed or recorded on PC with dedicated software.

Order No.	Model No.
010094	DP-10S • DP-10D SET

DIGITAL LEVEL SENSOR

New Product! Can be used as built in two-axis sensor for OEM equipment.

- USE** • Sensors for measurement and control of angle of inclination in machine tools, construction machinery, structures, etc.
- MATERIAL**
 - Case : Aluminum
- FEATURES**
 - Simultaneously measures angle of inclination in X and Y directions
 - When power applied, angle of inclination is output via RS-232C signal. (Power and output connection via terminal block)
 - Output from sensors can also be displayed or recorded on PC with dedicated software.



Measuring Range	± 9.998°
Minimum reading	0.002°
Operating temperature	0 ~ 40°C
Accuracy	± 0.01° (for measuring range less than ± 2°) ± 0.05° (for measuring range greater than ± 2°)
Repeatability	± 0.01°
XY orthogonal accuracy	1%
response time (measurement period)	approx. 2.5s
Output signal	Conforms to RS-232C
Power	DC9 to 15V (approx 70mA)
Dimensions	L105 × W75 × H53mm

DIMENSIONS

Units : mm

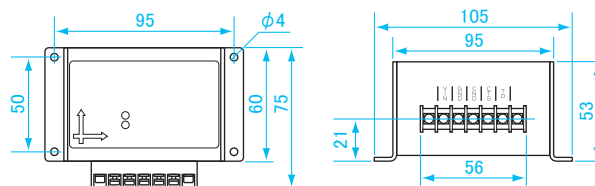

Order No.	Model No.	Weight
010096	DP-10M	270g



BEVEL BOX BB-180

Compact design digital angle meter



DIMENSIONS

Units : mm

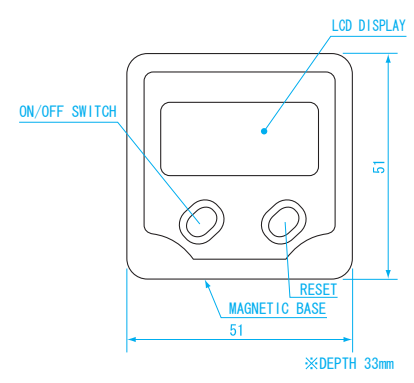

USE • For all processes that require precise angle measurement, such as assembly, molding, machining and fixtures.

MATERIALS • Aluminum frame, Plastic face/back, magnet on base

- FEATURES**
- Zero-setting at desired position
 - Auto power off function (after 5 min.)
 - One CR2032 (Lithium) battery included for testing

Order No.	Model No.	Measuring Range	Resolution	Operating Temperature	Accuracy*	Repeatability	Weight
010101	BB-180	± 180.0°	0.1°	5 ~ 45°C	± 0.2°	0.1°	120g

* Quantization Error (± 1 digit) not included

BEVEL BOX BB-180A

Compact design digital angle meter

Absolute measurement mode stores true horizontal



DIMENSIONS

Units : mm

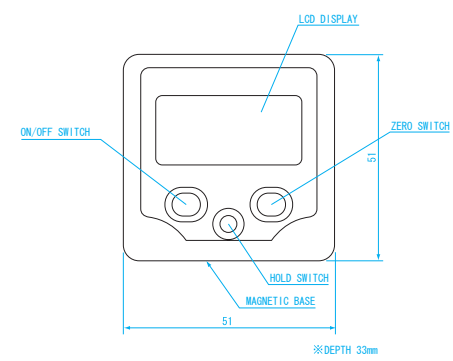

USE • For all processes that require precise angle measurement, such as assembly, molding, machining and fixtures.

MATERIALS • Body : Aluminum (with magnet on base)

- FEATURES**
- Zero setting at desired position
 - Absolute measurement mode stores true horizontal
 - "Hold" button to fix reading on display
 - Auto power off function (after 5 min.)
 - One CR2032 (Lithium) battery included for testing



Order No.	Model No.	Measuring Range	Resolution	Operating Temperature	Accuracy*	Repeatability	Weight
010102	BB-180A	± 180.0°	0.1°	5 ~ 45°C	± 0.2°	0.1°	170g

* Quantization Error (± 1 digit) not included

LEVEL METER LM-90



Analog type goniometer with magnetic base

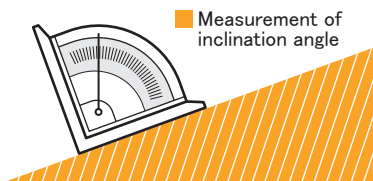

USE • Measurement of inclination angle

MATERIALS

- Plastic

FEATURES

- Analog dial easier to read than bubble tube type meter
- With magnetic base to enables measuring horizontal and vertical angle
- Light weight, easy to use

SPECIFICATIONS

- Measuring range : 0 ~ 90 °
- Graduation : 1 °
- Accuracy : ± 0.5 °

Order No.	Model No.	Dimensions (H) × (W) × (T) (mm)	Weight
011010	LM-90	95 × 95 × 30	120g

LEVEL MATE LM-360



Analog type goniometer With magnet for vertical surfaces

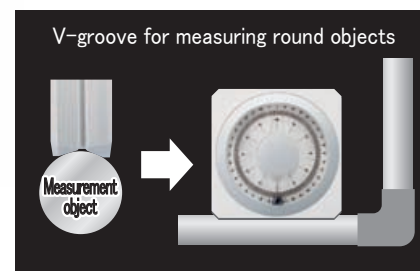

USE

- Angle of tilt measurement
- Mechanical assembly, installation
- Setting angles for machine work
- Miscellaneous plumbing work
- Construction and related work

MATERIALS

- Plastic

FEATURES

- V groove on bottom, magnet for vertical surface

SPECIFICATIONS

- Measurement range : 0 ~ 360 °
- Graduation : 1 °
- Reading accuracy : ± 0.5 °

Order No.	Model No.	Dimensions (H) × (W) × (T) (mm)	Weight
011030	LM-360	110 × 110 × 20	140g



DIAL SLANT RULE



Analog dial angle meter



DSR-ST

DSR-MG
(with magnet)

- USE** • Measurement of inclination angle
- MATERIALS** • Plastic
- FEATURES**
 - Analog dial easier to read than bubble tube type meter
 - Light weight and easy to use
- SPECIFICATIONS**
 - Measuring Range : 0 ~ 180 °
 - Graduation : 1 °
 - Accuracy : ± 0.5 °

Order No.	Model No.	Dimensions (L) × (H) × (W) (mm)	Weight
011000	DSR-ST	182 × 92 × 20	80g
011001	DSR-MG	182 × 92 × 20	90g

LEVEL POINT GAUGE

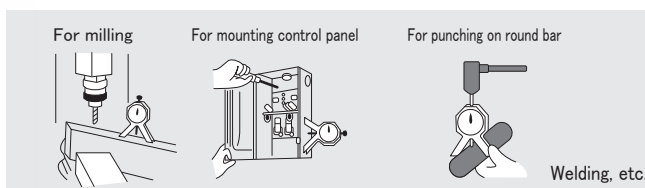

- USE** • Measure angle of round bar, or center punch at exact angle
- MATERIALS** • Body : Aluminum • Leg : Steel
- FEATURES**
 - One touch direct angle reading
 - You can quickly and accurately measure any angle from horizontal to vertical
 - Punch end is carbide tipped
 - Magnetic feet
- SPECIFICATIONS**
 - Measuring Range : 0 ~ 360 °
 - Accuracy : within 1 °
 - Graduation : 1 °
 - Applicable diameter for V base : $\phi 20 \sim 100\text{mm}$

DIMENSIONS

Units : mm

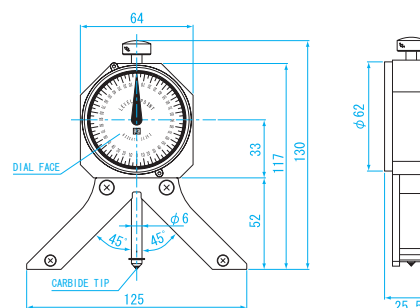

Order No.	Model No.	Dimensions (H) × (W) × (T) (mm)	Weight
011022	LP-360	130 × 125 × 25	400g



Horizontal, vertical, and 45° measurements in one level
Magnetic measuring surface (ALM series)



ALM-600

USE • Horizontal, vertical, and 45° measurements

MATERIAL

- Aluminum

FEATURES

- V-grooved measuring surface for convenient measurement on round objects
- Can measure 1/100 and 2/100 gradient.
- Magnifying lens on horizontal bubble tube for easy reading
- ALM type with magnet
- With scale on both sides

SPECIFICATIONS

- Horizontal bubble tube Sensitivity: 0.35mm/m=0.0201°
 Accuracy: ± 1.00mm/m= ± 0.0573°
- Vertical bubble tube Sensitivity: 0.50mm/m=0.0286°
 Accuracy: ± 1.50mm/m= ± 0.0859°

Order No.	Model No.	Type	Bubble tube type	Length (mm)	Height (mm)	Thickness (mm)	Weight
111200	ALM-150	with magnet	Horizontal	150	56	25	164g
111201	ALM-230	with magnet	Horizontal vertical	230	56	25	220g
111202	ALM-300	with magnet	Horizontal Vertical 45°	300	56	25	340g
111203	ALM-380	with magnet	Horizontal Vertical 45°	380	56	25	380g
111204	ALM-450	with magnet	Horizontal Vertical 45°	450	56	25	410g
111205	ALM-600	with magnet	Horizontal Vertical 45°	600	56	25	500g
111206	ALM-750	with magnet	Horizontal Vertical 45°	750	56	25	630g
111207	ALM-900	with magnet	Horizontal Vertical 45°	900	56	25	770g
111208	ALM-1200	with magnet	Horizontal Vertical 45°	1200	56	25	930g
111209	ALM-1500	with magnet	Horizontal Vertical 45°	1500	56	25	1200g
111210	ALM-1800	with magnet	Horizontal Vertical 45°	1800	56	25	1340g
111211	ALS-150	—	Horizontal	150	56	25	100g
111212	ALS-300	—	Horizontal Vertical 45°	300	56	25	194g
111213	ALS-380	—	Horizontal Vertical 45°	380	56	25	234g
111214	ALS-450	—	Horizontal Vertical 45°	450	56	25	270g
111215	ALS-600	—	Horizontal Vertical 45°	600	56	25	345g
111216	ALS-900	—	Horizontal Vertical 45°	900	56	25	492g
111217	ALS-1200	—	Horizontal Vertical 45°	1200	56	25	622g

ANGLE

LEVELNIC

PRECISION LEVEL

ANGLE LEVEL

LEVEL

PROTRACTOR



GRADE LEVEL



- USE**
 - Measuring horizontal, vertical
- MATERIALS**
 - Body : Aluminum

- FEATURES**
 - Luminous vial can be seen clearly, even in the dark
 - Graduations at 1/100, 2/100 inclination value
 - Vial has large lens for easy reading
 - GLM type are with magnet

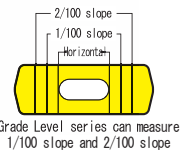

Sensitivity is the amount of gradient required to make the bubble move.
Precision [$0^\circ \pm$ precision value] is the range of variation in the reading

Order No.	Model No.	Length (mm)	Height (m)	Thickness (mm)	Sensitivity (mm/m)	Precision (mm/m)	Weight	Note
011049	GL-230	230	45	22	0.35	± 1.00	190g	
011050	GL-300	300	45	22	0.35	± 1.00	220g	
011051	GL-380	380	45	22	0.35	± 1.00	270g	
011052	GL-450	450	45	22	0.35	± 1.00	300g	
011053	GL-600	600	45	22	0.35	± 1.00	390g	
011054	GL-900	900	45	22	0.35	± 1.00	560g	
011060	GLM-300	300	50	20	0.35	± 1.00	320g	with magnet
011061	GLM-380	380	50	20	0.35	± 1.00	360g	with magnet
011062	GLM-450	450	50	20	0.35	± 1.00	400g	with magnet
011063	GLM-600	600	50	20	0.35	± 1.00	460g	with magnet

MINI LEVEL



- USE** • Horizontal measurements for construction, installation, and leveling machinery
- MATERIALS** • Acrylic resin, aluminum, cast iron

Sensitivity is the amount of gradient required to make the bubble move.
Precision [$0^\circ \pm$ precision value] is the range of variation in the reading

Order No.	Model	Type	Length (mm)	Height (mm)	Thickness (mm)	Sensitivity (mm/m)	Precision (mm/m)	Weight
011070	CT-70	Acrylic resin/ Cross	70	25	15	0.5	± 1.5	40g
011071	CS-70	Acrylic resin/ Scale	70	35	12	0.5	± 2.5	40g
011072	CR-24	Acrylic resin/ Round	ϕ 24	—	10	0.5	± 2.5	10g
011077	A-90-13	Aluminum/ Hex	90	13	—	0.5	± 1.5	20g
011078	A-90-17	Aluminum/ Hex	90	17	—	0.5	± 1.5	50g
011079	A-105-13	Aluminum/ Hex	105	13	—	0.5	± 1.5	20g
011080	A-105-17	Aluminum/ Hex	105	17	—	0.5	± 1.5	50g
011081	S-65	Aluminum/ Straight	65	20	14	0.5	± 1.5	40g
011082	S-90	Aluminum/ Straight	90	20	14	0.5	± 1.5	50g
011083	T-50	Aluminum/ Flat	50	30	15	0.5	± 1.5	50g
011084	T-100	Aluminum/ Flat	100	30	15	0.5	± 1.5	120g
011085	F-90	Cast iron	90	20	30	0.5	± 1.5	180g



SUPER STRONG MAGNETIC LEVEL

Twice as strong as our other magnetic levels



USE • Horizontal, vertical, and 45° measurements

MATERIAL • Plastic

FEATURES

- Magnetic measuring surface (Attraction force: 118N)
- V-grooved measuring surface for convenient measurement on round objects

SPECIFICATIONS

- Bubble tube sensitivity: $0.50\text{mm/m} = 0.0286^\circ$
- Vial accuracy: within $\pm 1.50\text{mm/m} = \pm 0.0859^\circ$
- 4-line acrylic bubble tube with phosphorescent tape with 360° acrylic spot level (ML-100KB • ML-100KW)

Order No.	Model No.	Color	Bubble tube type	Length (mm)	Height (m)	Thickness (mm)	Weight
111218	ML-100KB	Black	Horizontal - Vertical	100	47	20	80g
111219	ML-100KW	White	Horizontal - Vertical	100	47	20	80g
111220	ML-150KB	Black	Horizontal - Vertical - 45°	150	47	20	110g
111221	ML-150KW	White	Horizontal - Vertical - 45°	150	47	20	110g

MEMO

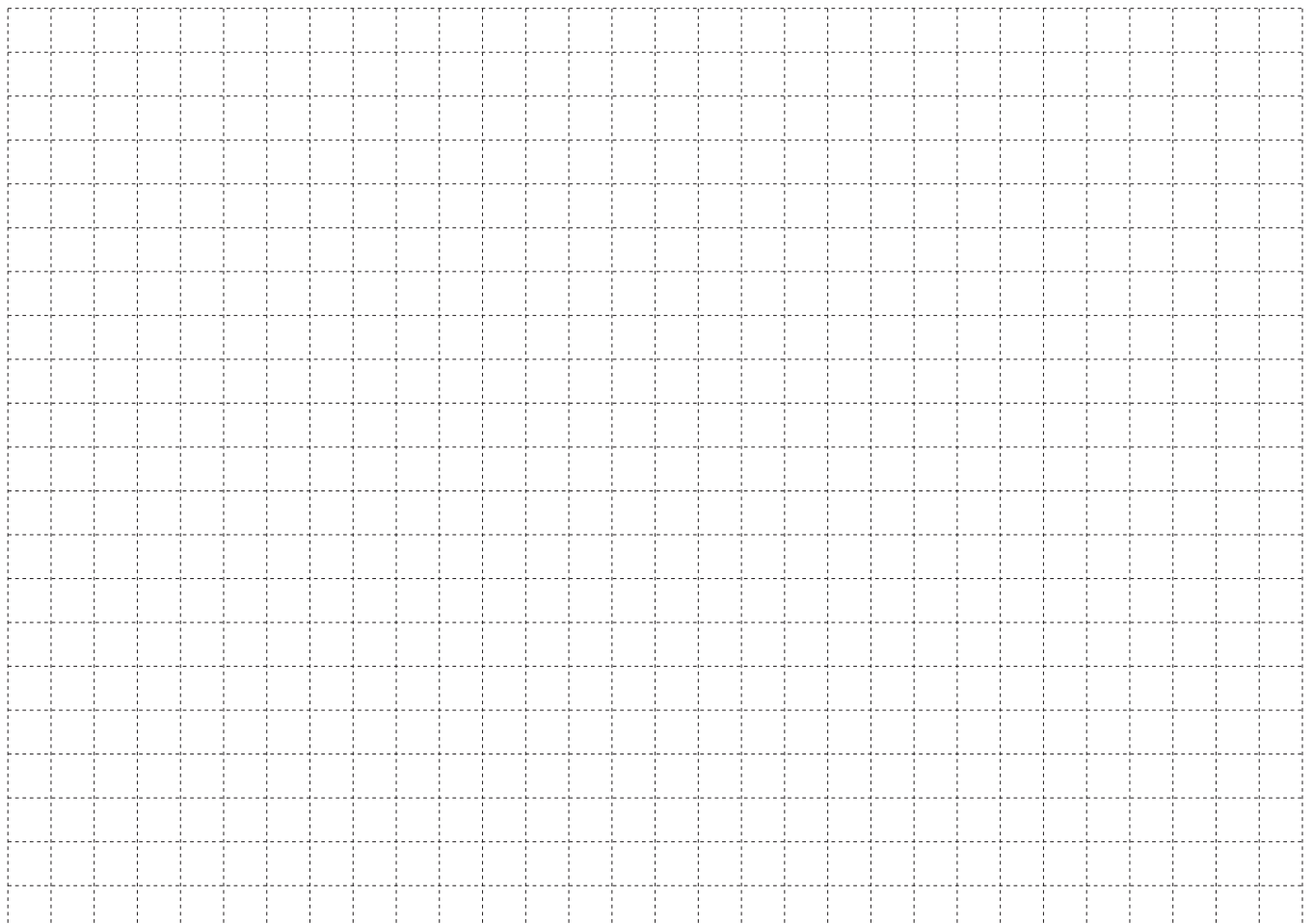

ANGLE

LEVELNIC

PRECISION
LEVELANGLE
LEVEL

LEVEL

PROTRA
CTOR



PROTRACTOR No.15



MATERIALS • Stainless steel (SUS420J2)

FEATURES

- Graduation on blade
- With rectangle head
- The blade is firmly set on the center of the protractor by a knurled nut and adjustable to any desired angle for use as a protractor
- Also can measure depth

SPECIFICATIONS

- Protractor size: (H)52mm × (W)90mm × (T)1.2mm
- Graduation : 1°
- Maximum angle : 180°
- Accuracy : ± 20'
- Blade size : (L)177mm × (T)1.2mm
150mm scale (Graduation: 0.5mm)

Order No.	Model No.	Weight
008000	PRT-15	80g

PROTRACTOR No.19



No.19 Graduation on blade



For angle measurement

MATERIALS

- Stainless steel (SUS420J2)

FEATURES

- Graduation on blade
- Polished finish



SPECIFICATIONS

- Protractor size : φ 90mm × (T)1.2mm
- Graduation : 1°
- Maximum angle : 180°
- Accuracy : ± 20'
- Blade size : (L)204mm × (T)1.2mm
100mm scale (Graduation: 1mm)

Order No.	Model No.	Weight
008001	PRT-19	81g

PROTRACTOR No.19



No.19 with two blades



MATERIALS

- Stainless steel (SUS420J2)

FEATURES

- With 2 blades
- Can measure acute angle down to 10°
- Satin finish

SPECIFICATIONS

- Graduation : 1°
- Maximum angle : 180°
- Accuracy : ± 20'
- Size: φ 90mm × (T)1.2mm
- Blade size: (L)204 × (T)1.2mm

Order No.	Model No.	Weight
008002	PRT-19SW	110g

PROTRACTOR No.19



No. 19 Satin finish



MATERIALS

- Stainless steel (SUS420J2)

FEATURES

- Graduation on blade
- Satin finish

SPECIFICATIONS

- Graduation: 1°
- Maximum angle : 180°
- Accuracy : ± 20'
- Size: φ 90mm × (T)1.2mm
- Blade size: (L)204mm × (T)1.2mm
100mm scale (Graduation: 1mm)

Order No.	Model No.	Weight
008003	PRT-19S	81g

PROTRACTOR No.19A



MATERIALS

- Stainless steel (SUS420J2)

FEATURES

- Cutout for measuring small angle
- Polished finish

SPECIFICATIONS

- Protractor size : ϕ 90mm \times (T)1.2mm
- Graduation: 1°
- Maximum angle : 90°
- Accuracy $\pm 20'$
- Blade : (L)204mm \times (T)1.2mm

Order No.	Model No.	Weight
008004	PRT-19A	90g

PROTRACTOR No.19B



MATERIALS

- Stainless steel (SUS420J2)

FEATURES

- Protractor blade contains stop for setting a baseline angle and measuring against that set point
- Polished finish

SPECIFICATIONS

- Protractor size : ϕ 90mm \times (T)1.2mm
- Graduation : 1°
- Maximum angle : 180°
- Accuracy : $\pm 20'$
- Blade : (L)204mm \times (T)1.2mm

Order No.	Model No.	Weight
008005	PRT-19B	90g

PROTRACTOR No.182



MATERIALS

- Stainless steel (SUS420J2)

FEATURES

- Center lock nut has a built in needle for marking center point
- Satin finish

SPECIFICATIONS

- Protractor size : ϕ 90mm \times (T)1.2mm
- Graduation : 1°
- Maximum angle : 180°
- Accuracy : $\pm 20'$
- Blade : (L)204mm \times (T)1.2mm

Order No.	Model No.	Weight
008182	PRT-182S	155g

PROTRACTOR No.183

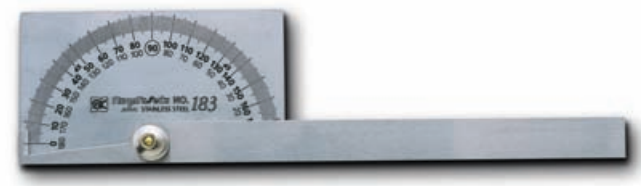

MATERIALS

- Stainless steel (SUS420J2)

FEATURES

- With rectangle head
- Satin finish

SPECIFICATIONS

- Protractor size:(H)52mm \times (W)90mm \times (T)1.2mm
- Graduation : 1°
- Maximum angle : 180°
- Accuracy : $\pm 20'$
- Blade : (L)204mm \times (T)1.2mm

Order No.	Model No.	Weight
008183	PRT-183S	90g





PROTRACTOR No.30



PROTRACTOR No.101



MATERIALS

- Stainless steel (SUS420J2)

FEATURES

- Angle measurement
- Satin finish

SPECIFICATIONS

- Protractor size : ϕ 120mm \times Thickness 1.5mm
- Graduation : 1°
- Maximum angle : 180°
- Accuracy : $\pm 15'$
- Blade size : (L)315mm \times (T)1.5mm

Order No.	Model No.	Weight
008030	PRT-30S	190g

MATERIALS

- Stainless steel (SUS420J2)

FEATURES

- Blade can be fixed. Ideal for work requiring high accuracy
- Satin finish

SPECIFICATIONS

- Protractor size : ϕ 120mm \times (T)1.5mm
- Graduation : 1°
- Maximum angle : 180°
- Accuracy : $\pm 15'$
- Blade size : 304mm \times (T)1.5mm

Order No.	Model No.	Weight
008101	PRT-101S	158g

PROTRACTOR No.300 • No.400 • No.600 • No.1000



PRT-400S



PRT-400SW

MATERIALS

- Stainless steel (SUS420J2)

FEATURES

- Large size protractors
- Satin finish

SPECIFICATIONS

- Graduation : 0.5°
- Maximum angle : 180°
- Accuracy : $\pm 15'$

Order No.	Model No.	Size	Diameter (mm)	Thickness (mm)	Number of blade	Blade Length (mm)	Blade Thickness (mm)	Graduation on Blade	Weight
008300	PRT-300S	300mm	210	2.0	1	500	2.0	300mm (1mm step)	610g
008400	PRT-400S	400mm	250	2.0	1	634	2.0	400mm (1mm step)	700g
008600	PRT-600S	600mm	320	2.5	1	823	2.5	600mm (1mm step)	1.6kg
008700	PRT-1000S	1000mm	320	2.5	1	1260	2.5	1000mm (1mm step)	2kg
008302	PRT-300SW	300mm	210	2.0	2	489	2.0	300mm (1mm step)	670g
008402	PRT-400SW	400mm	250	2.0	2	634	2.0	400mm (1mm step)	1.1kg
008602	PRT-600SW	600mm	320	3.2	2	823	2.5	600mm (1mm step)	2.45kg
008702	PRT-1000SW	1000mm	320	3.2	2	1260	2.5	1000mm (1mm step)	3.15kg



INSIDE PROTRACTOR



Measure interior angles in one step
Measurements at a glance

Example of use

DIMENSIONS Units : mm

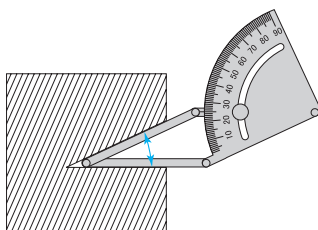
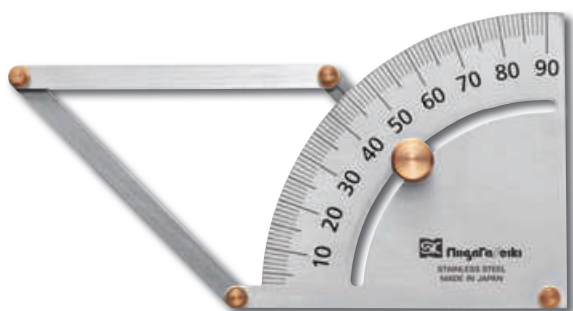

Measurement of interior angles

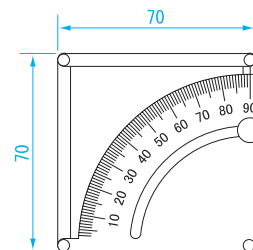

USE • Measurement of interior angles

MATERIAL

- Stainless steel (SUS410)

FEATURES

- Measure interior angles at a glance
- Silver matte finish for easy to read scale
- With plastic case for convenient transport

Order No.	Model No.	Graduation	Angle measurement range	Accuracy	Weight
007517	IP-90	1°	10°~90°	±0.5°	43g

PROTRACTOR No.192



PRT192-120S

USE • Set attachment angle for machines and jigs

MATERIALS

- Stainless steel (SUS420J2)

FEATURES

- Polished finish : PRT192-90S
- Satin finish : PRT192-120S • PRT192-200S • PRT192-250S • PRT192-300S

Order No.	Model No.	Graduation	Maximum Angle	Diameter (mm)	Thickness (mm)	Accuracy	Weight	Note
008901	PRT192-90S	1°	180°	90	1.2	±20'	40g	Polished finish
008903	PRT192-120S	1°	180°	120	1.5	±20'	80g	Satin finish
008930	PRT192-200S	0.5°	180°	210	2.0	±15'	310g	Satin finish
008940	PRT192-250S	0.5°	180°	250	2.0	±15'	440g	Satin finish
008960	PRT192-300S	0.5°	180°	320	2.5	±15'	870g	Satin finish

PROTRACTOR No.193



PRT193-150

USE • Set attachment angle for machines and jigs

MATERIALS

- Stainless steel (SUS420J2)

FEATURES

- Satin finish
- A circle plate protractor

Order No.	Model No.	Graduation	Maximum angle	Diameter (mm)	Thickness (mm)	Accuracy	Weight
009109	PRT193-90	1°	360°	90	1.2	±20'	60g
009112	PRT193-120	1°	360°	120	1.5	±20'	140g
009115	PRT193-150	1°	360°	150	1.5	±20'	210g
009120	PRT193-200	1°	360°	200	2.0	±20'	510g
009125	PRT193-250	1°	360°	250	2.0	±20'	780g
009130	PRT193-300	1°	360°	300	2.5	±20'	1.38kg



UNIVERSAL BEVEL PROTRACTOR

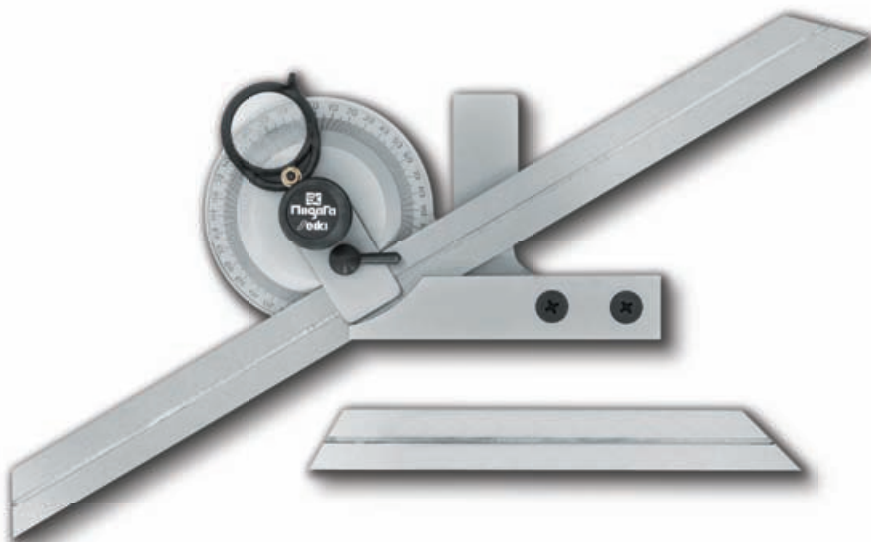

USE • Angle measurement

MATERIALS

- Body: Carbon tool steel
- Blade: Stainless steel

FEATURES

- Extremely fine measurement of accurate angles can be obtained from this protractor by simply rotating the ultra sensitive adjustment knob.
- Attached magnification lens on the front of the protractor permits reading and setting of angles accurately and easily.

SPECIFICATIONS

- Graduation: 1°
- Minimum reading: 5' (or 1/12 degree)
- Interchangeable blade: 150mm and 300mm

Order No.	Model No.	Product Dimensions (mm)	Weight
151052	495D	140 × 73 × 10	400g

DIGITAL UNIVERSAL PROTRACTOR



With master speed square, precision measurement without reading error



USE • Precise angle measurement for tooling and fixtures, assembly, machining, mold making, and for use as a standard

MATERIALS

- Body : Carbon tool steel
- Blade : Stainless steel

FEATURES

- Quick display of the measured value
- One CR2032 (Lithium) battery included for testing

SPECIFICATIONS

- Minimum reading: 30" (0.008°)
- Resolution: 10"
- Repeatability : 1' (0.0167°)
- Interchangeable blade : 150mm and 300mm

Order No.	Model No.	Product Dimensions (mm)	Weight
151050	DUP-360	135 × 71 × 34	350g

※ Quantization Error (± 1 digit) not included

FOR MORE INFORMATION PLEASE CONTACT :



BHAGWATI HARDWARE & MILL STORE

4769, 1ST Floor, Old Post Office Building,
Hauz Qazi, Delhi- 110006.

Ph : 011-66405958, 45025958,

Mobile : 9212012856, 9350076343

Website : www.bhagwathardwaredelhi.in

e-mail : sandeep@bhagwatimail.com

AN ISO 9001 : 2015 CERTIFIED COMPANY