



## Precision Square Level

To measure...			
Flatness	Straightness	Squareness	Parallelism
○	○	◎	○

Stock No.541AA (JIS Standard)

Grade AA (JIS) Traceability

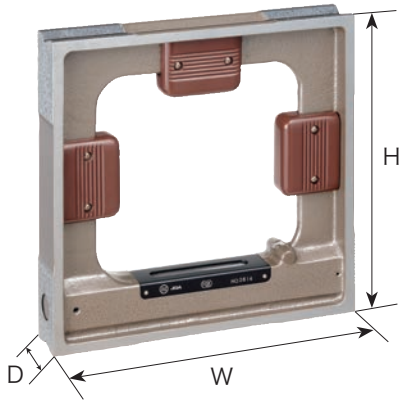

Stock No.541A (JIS Standard)

Grade A (JIS) Traceability



Stock No.541B (JIS Standard)

Grade B (JIS) Traceability



SIZE	W × H × D (mm)	Sensitivity (mm/m)	Net Weight (kg)
150	150 × 150 × 40	0.02 ( 4" ) 0.05 (10" ) 0.1 (20" )	2.1
200	200 × 200 × 42		3.8
250	250 × 250 × 50		5.8
300	300 × 300 × 50		7.5

- Grade AA, A and B are manufactured and inspected under the JIS B 7510 standard. ( See P5. for further information on each grade. )
- Grade AA has ±0.2 scale all range accuracy in the main bubble.
- These three types have less than 3µm accuracy in flatness between base and side. ( 0.02mm/m type )
- Squareness between base and both side is 0.015mm/m. ( 0.02mm/m for Grade A )
- Grade AA and Grade A have a bubble chamber in which the length of the bubble is manually adjustable.

Stock No.541

Standard Type (NOT JIS standard) Traceability

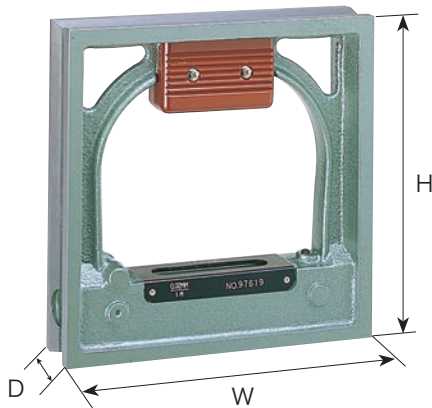

SIZE	W × H × D (mm)	Sensitivity (mm/m)	Net Weight (kg)
100	100 × 100 × 38	0.02 ( 4" ) 0.05 (10" ) 0.1 (20" )	1.0
150	150 × 150 × 42		2.1
200	200 × 200 × 42		3.8
250	250 × 250 × 45		5.8
300	300 × 300 × 45		7.5

### ■ About Sensitivity

Sensitivity (mm/m) represents either height or angle of gradient which is required to move main bubble a scale.

For example, you will know there is 0.02mm height difference 1m away from where you measure, when the main bubble moves a scale.

### ■ NOTE

- 0.02mm/m is 4 seconds = 0.0011°
- 0.05mm/m is 10 seconds = 0.00277°
- 0.1mm/m is 20 seconds = 0.0055°

**Code Number of Precision Square Level**

	Code Number	Size	Sensitivity	Net Weight (kg)
Grade AA	541-1502AA	150	0.02	2.1
	541-2002AA	200		3.8
	541-2502AA	250		5.8
	541-3002AA	300		7.5
	541-1505AA	150	0.05	2.1
	541-2005AA	200		3.8
	541-2505AA	250		5.8
	541-3005AA	300		7.5
	541-1501AA	150	0.1	2.1
	541-2001AA	200		3.8
	541-2501AA	250		5.8
	541-3001AA	300		7.5
Grade A	541-1502A	150	0.02	2.1
	541-2002A	200		3.8
	541-2502A	250		5.8
	541-3002A	300		7.5
	541-1505A	150	0.05	2.1
	541-2005A	200		3.8
	541-2505A	250		5.8
	541-3005A	300		7.5
	541-1501A	150	0.1	2.1
	541-2001A	200		3.8
	541-2501A	250		5.8
	541-3001A	300		7.5
Grade B	541-1502B	150	0.02	2.1
	541-2002B	200		3.8
	541-2502B	250		5.8
	541-3002B	300		7.5
	541-1505B	150	0.05	2.1
	541-2005B	200		3.8
	541-2505B	250		5.8
	541-3005B	300		7.5
	541-1501B	150	0.1	2.1
	541-2001B	200		3.8
	541-2501B	250		5.8
	541-3001B	300		7.5
Standard Type	541-1002	100	0.02	1.0
	541-1502	150		2.1
	541-2002	200		3.8
	541-2502	250		5.8
	541-3002	300		7.5
	541-1005	100	0.05	1.0
	541-1505	150		2.1
	541-2005	200		3.8
	541-2505	250		5.8
	541-3005	300		7.5
	541-1001	100	0.1	1.0
	541-1501	150		2.1
	541-2001	200		3.8
	541-2501	250		5.8
541-3001	300	7.5		



# PRECISION LEVEL

## Precision Flat Level

To measure...			
Flatness	Straightness	Squareness	Parallelism
◎	○	×	○

Stock No.542AA  
Grade AA (JIS) Traceability



Stock No.542A  
Grade A (JIS) Traceability



Stock No.542 B  
Grade B (JIS) Traceability



### Work Measurement: Grade AA and Grade A

SIZE	W × H × D (mm)	Sensitivity (mm/m)	Net Weight (kg)
150	150 × 45 × 49	0.02 ( 4" ) 0.05 (10" ) 0.1 (20" )	1.3
200	200 × 48 × 49		1.7
250	250 × 48 × 49		2.3
300	300 × 48 × 49		2.8

### Work Measurement: Grade B

SIZE	W × H × D (mm)	Sensitivity (mm/m)	Net Weight (kg)
150	150 × 48 × 47	0.02 ( 4" ) 0.05 (10" ) 0.1 (20" )	1.3
200	200 × 48 × 47		1.7
250	250 × 48 × 47		2.3
300	300 × 48 × 47		2.8

Stock No.542  
Standard Type (NOT JIS standard) Traceability

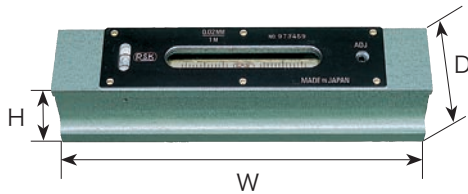

### Work Measurement: Standard type

SIZE	W × H × D (mm)	Sensitivity (mm/m)	Net Weight (kg)
100	100 × 48 × 47	0.02 ( 4" ) 0.05 (10" ) 0.1 (20" )	0.8
150	150 × 48 × 47		1.3
200	200 × 48 × 47		1.7
250	250 × 48 × 47		2.3
300	300 × 48 × 47		2.8
450	450 × 52 × 50		4.5
600	600 × 52 × 50		6.0

- Grade AA, A and B are manufactured and inspected under the JIS B 7510 standard. ( See P5. for further information on each grade. )

- Grade AA has ±0.2 scale all range accuracy in the main bubble

- Grade AA and Grade A have an insulating material which prevents heat transferring.

- Grade AA and Grade A have a bubble chamber in which the length of the bubble is manually adjustable.

**FOR MORE INFORMATION PLEASE CONTACT :**



### BHAGWATI HARDWARE & MILL STORE

4769, 1ST Floor, Old Post Office Building,  
Hauz Qazi, Delhi- 110006.

Ph : 011-66405958, 45025958,

Mobile : 9212012856, 9350076343

Website : www.bhagwathardwaredelhi.in

e-mail : sandeep@bhagwatimail.com

**AN ISO 9001 : 2015 CERTIFIED COMPANY**



# PRECISION LEVEL

	Code Number	Size	Sensitivity	Net Weight (kg)
Grade AA	542-1502AA	150	0.02	1.3
	542-2002AA	200		1.7
	542-2502AA	250		2.3
	542-3002AA	300		2.8
	542-1505AA	150	0.05	1.3
	542-2005AA	200		1.7
	542-2505AA	250		2.3
	542-3005AA	300		2.8
	542-1501AA	150	0.1	1.3
	542-2001AA	200		1.7
	542-2501AA	250		2.3
	542-3001AA	300		2.8
Grade B	542-1502A	150	0.02	1.3
	542-2002A	200		1.7
	542-2502A	250		2.3
	542-3002A	300		2.8
	542-1505A	150	0.05	1.3
	542-2005A	200		1.7
	542-2505A	250		2.3
	542-3005A	300		2.8
	542-1501A	150	0.1	1.3
	542-2001A	200		1.7
	542-2501A	250		2.3
	542-3001A	300		2.8
Grade A	542-1502B	150	0.02	1.3
	542-2002B	200		1.7
	542-2502B	250		2.3
	542-3002B	300		2.8
	542-1505B	150	0.05	1.3
	542-2005B	200		1.7
	542-2505B	250		2.3
	542-3005B	300		2.8
	542-1501B	150	0.1	1.3
	542-2001B	200		1.7
	542-2501B	250		2.3
	542-3001B	300		2.8
Standard Type	542-1002	100	0.02	0.8
	542-1502	150		1.3
	542-2002	200		1.7
	542-2502	250		2.3
	542-3002	300		2.8
	542-4502	450		4.5
	542-6002	600	6.0	
	542-1005	100	0.05	0.8
	542-1505	150		1.3
	542-2005	200		1.7
	542-2505	250		2.3
	542-3005	300		2.8
	542-4505	450		4.5
	542-6005	600	6.0	
	542-1001	100	0.1	0.8
	542-1501	150		1.3
	542-2001	200		1.7
	542-2501	250		2.3
542-3001	300	2.8		
542-4501	450	4.5		
542-6001	600	6.0		



# PRECISION LEVEL

## Code Number of Precision Square Level

### About Grade

Under the JIS standard, guarantee level is different from each grades.

※ Grade AA is our original standard. It adopts more strict inspections than JIS standard.

### Precision Square Level

Item		Grade AA			Grade A ( JIS B 7510 )			Grade B ( JIS B 7510 )		
		Class 1	Class 2	Class 3	Class 1	Class 2	Class 3	Class 1	Class 2	Class 3
Allowable error of main bubble	All Range	±0.2 Scale or less			±0.5 Scale or less	±0.3 Scale or less		±0.7 Scale or less	±0.5 Scale or less	
	Adjacent Scale	0.2 Scale or less			0.2 Scale or less			0.5 Scale or less		
Squareness bottom to side surface		0.015mm/m or less	0.025mm/m or less		0.015mm/m or less	0.025mm/m or less		0.02mm/m or less	0.035mm/m or less	
Parallelism v groove to surface with v groove		0.5 Scale or less			0.5 Scale or less			0.5 Scale or less		
Parallelism bottom to top side		0.5 Scale or less			0.5 Scale or less			0.5 Scale or less		
Flatness bottom to side surface		0.003mm or less	0.005mm or less		0.003mm or less	0.005mm or less		0.003mm or less	0.005mm or less	

### Precision Flat Level

Item		Grade AA			Grade A ( JIS B 7510 )			Grade B ( JIS B 7510 )		
		Class 1	Class 2	Class 3	Class 1	Class 2	Class 3	Class 1	Class 2	Class 3
Allowable error of main bubble	All Range	±0.2 Scale or less			±0.5 Scale or less	±0.3 Scale or less		±0.7 Scale or less	±0.5 Scale or less	
	Adjacent Scale	0.2 Scale or less			0.2 Scale or less			0.5 Scale or less		
Parallelism v groove to surface with v groove		0.5 Scale or less			0.5 Scale or less			0.5 Scale or less		
Flatness bottom surface		0.003mm or less	0.005mm or less		0.003mm or less	0.005mm or less		0.003mm or less	0.005mm or less	

## Magnetic Square Type Precision Level

Stock No. 583

“Grade A” class Traceability

To measure...			
Flatness	Straightness	Squareness	Parallelism
○	○	◎	○

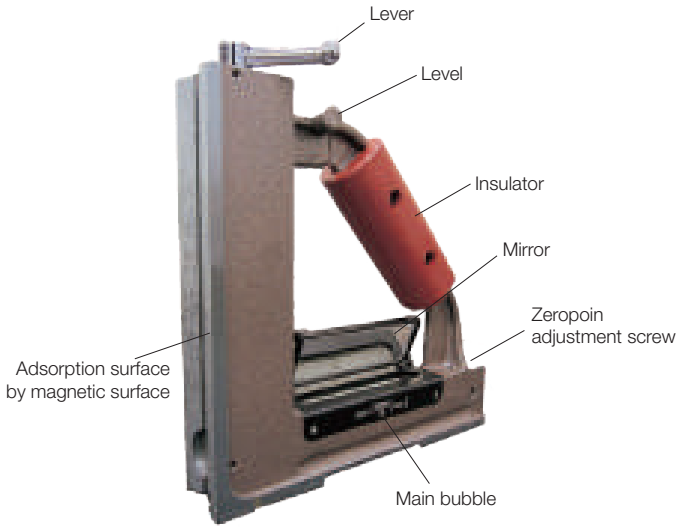

- Side surface is magnetic. It is designed for measuring cylindrical configuration specially.
- This is also useful for operations in high-place as it can be held by its magnetic surface.
- The mirror allows you to read the number on the main bubble.
- Main bubble is as accurate as Grade A (JIS)

Code #	Size	Sensitivity mm/m	Mirror	Net Weight (kg)		
583-1502	150	0.02	Without	2.2		
583-1505		0.05				
583-1501		0.1				
583-2002	200	0.02	With	3.2		
583-2005		0.05				
583-2001		0.1				
583-2502	250	0.02				4.9
583-2505		0.05				
583-2501		0.1				

※ Size 150mm is not have a mirror

### Work Measurement

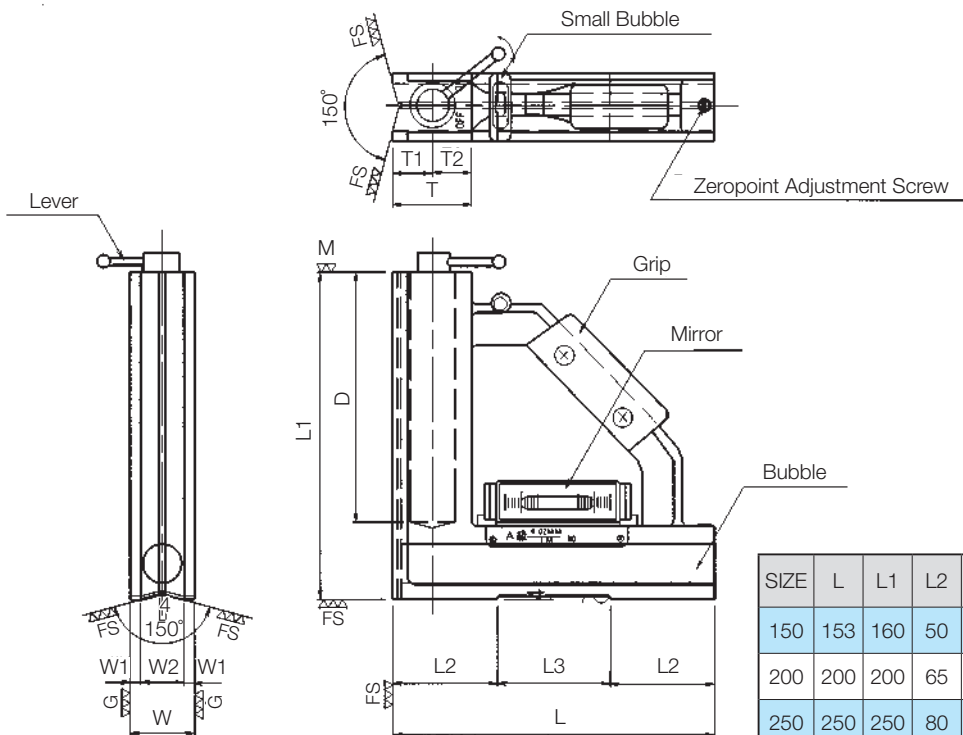

SIZE	L	L1	L2	L3	W	W1	W2	D	T	T1	T2
150	153	160	50	60	35	6.5	22	112	42	18	24
200	200	200	65	70	40	6.5	27	152	45	21	24
250	250	250	80	90	41	6.5	28	201	47	22	25



# PRECISION LEVEL

## Magnetic Square Type Precision For LM Guide

Stock No. 583-LM

“Grade A” class

Traceability

To measure...			
Flatness	Straightness	Squareness	Parallelism
○	○	◎	○

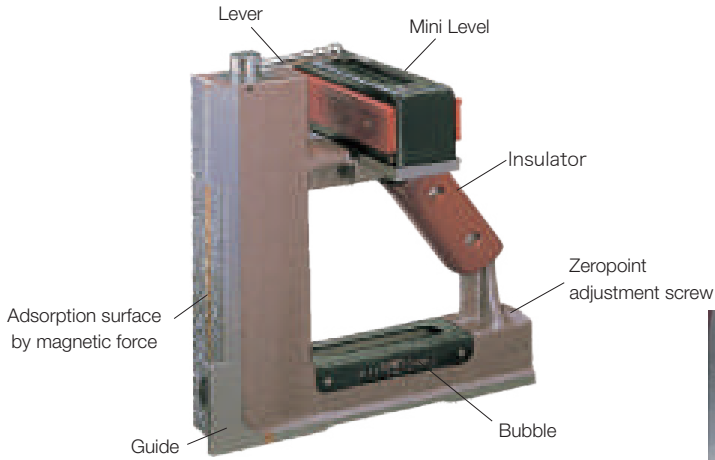

- It is best for checking squareness of a machine with LM guide.
- This measures the squareness between X-axis and Y-axis by putting its Guide on measuring object.
- Adsorption surface has flat surface instead of V groove.

Code #	Size	Sensitivity mm/m	Net Weight (kg)
583-1502LM	150	0.02	3.4
583-1505LM		0.05	

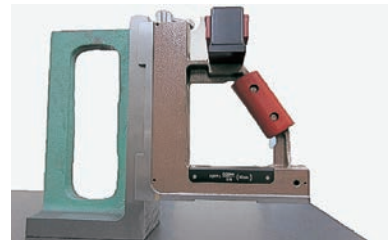
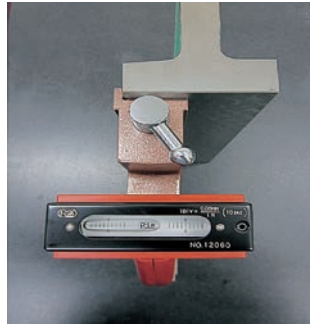

### Work Measurement

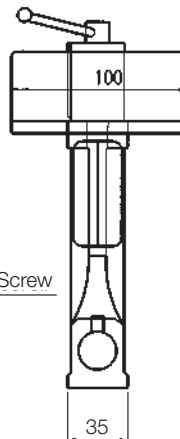
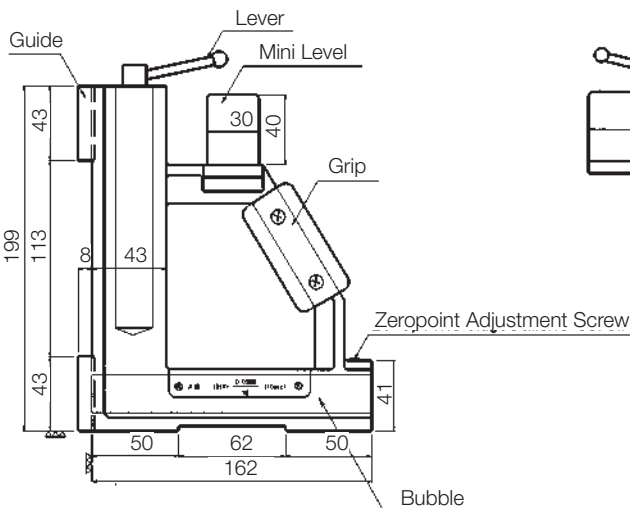
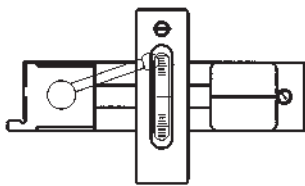

- Main bubble is as accurate as Grade A (JIS)
- Mini level helps reading more strict inspection.
- User can measure with his/her hand off as its adsorption surface is magnetized.



# PRECISION LEVEL

## Mini Level

Stock No. 584 Traceability

“Grade A” class



To measure...			
Flatness	Straightness	Squareness	Parallelism
◎	○	×	○

- Main bubble is as accurate as Grade A (JIS)
- In spite of its small size ( 100mm length ), the chamber adjusts the length of the main bubble.
- Good for storage and carriage.
- Parallelism v groove to surface with v groove is 0.5 scale.

Unit = mm

Code #	Wide	Depth	Height	Sensitivity (mm/m)	Net Weight (kg)
584-1002	100	33	45	0.02	0.5
584-1005	100	33	45	0.05	0.5

## Precision High Level

Stock No.740



740A



740B

To measure...
Zero point adjustment

- The smallest size among our precision levels. (100mm length and 25mm Height )
- Easy to check the zero point, just put it.
- Main bubble is as accurate as standard type.

Unit = mm

Code #	Model	Sensitivity (mm/m)	W × D × H	Diameter × Distance	Net Weight (kg)
740A05	740A	0.05	100 × 22 × 25	φ4.5 × 90	0.19
740A01		0.1			
740B02	740B	0.02	100 × 18 × 20	—	0.15
740B05		0.05			
740B01		0.1			

## Cross-Test Precision Level T-type

Stock No.600 Traceability



To measure...			
Flatness	Straightness	Squareness	Parallelism
◎	○	×	○

- Measures X-axis and Y-axis at one time.
- Both levels have zero point adjustment.
- Main bubble is as accurate as standard type.

Unit = mm

Code #	Sensitivity (mm/m)	L × W × D × H	Net Weight (kg)
600-2005	0.05	200 × 150 × 30 × 30	1.9
600-2001	0.1		
600-2002	0.2		





# PRECISION LEVEL

## Portable Level

Stock No. 252

To measure...			
Flatness	Straightness	Squareness	Parallelism
○	○	×	○



- This is especially designed for portable use.
- It has zeropoint adjustment.
- The sensitivity is as good as standard Type.

Unit = mm

Code #	Wide	Depth	Height	Sensitivity (mm/m)	Net Weight (kg)
252-02	100	27	27	0.02	0.34
252-05				0.05	
252-01				0.1	

## Measuring Level Center

Stock No.501



- It makes it easier to adjust zero point adjustment. no need of surface plate.

Code #
501

## Pocket Level

Stock No.572



- Nickel-plated level in hexagonal shape.

Unit = mm

Code #	Size	Hex shape average	Net Weight (kg)
572-65	65	10	0.04
572-90	90	12	0.05

## Square Type Cross Test Level

Stock No.574



- Made of cast iron and its surface is plated.
- Good for measuring flatness and installation of the machines.

Unit = mm

Code #	L	W	H	D	Net Weight (kg)
574-75HV	75	50	18	15	0.18

## Cross Test Level

Stock No.575

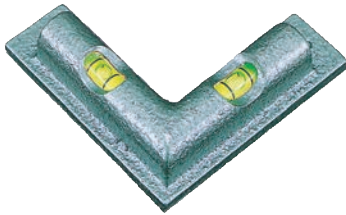

- Made of cast iron.
- Good for measuring flatness and installation of the machines.

Unit = mm

Code #	L	W	H	D	Height (kg)
575-65	65	65	18	15	0.23

## Round Level

Stock No.576

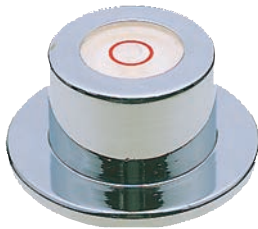

- When bubbles meet the center, the flatness is proven.
- It can be attached to any machines and scales.

Unit = mm

Code #	Outside Diameter × Diameter of Brim × Height	Net Weight (kg)
576-181	$\phi$ 18 × $\phi$ 28 × 14	0.02
576-201	$\phi$ 20 × $\phi$ 30 × 15	0.03
576-241	$\phi$ 24 × $\phi$ 35 × 18	0.05
576-251	$\phi$ 25 × $\phi$ 38 × 18	0.08

Unit = mm

Code #	Outside Diameter × Height	Net Weight (kg)
576-200	20 × 20	0.04
576-240	24 × 20	0.05

## Small Bench Level

Stock No.573

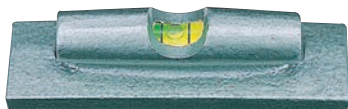

- Cast-iron level.

Unit = mm

Code #	Size	Net Weight (kg)
573-90	90	0.25

## Precision Square With Base ( JIS B 7526 )

Stock No.546-1, 546-2

Traceability



- This is essential to measure straightness.
- First class is hardened.

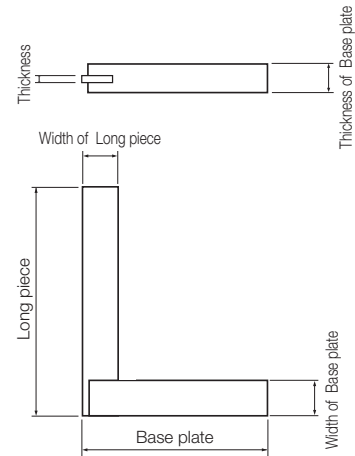

Unit = mm

	Code #	Nominal Size	Long piece	Base plate	Width of Long piece	Thickness of Long piece	Width of Base plate	Thickness of Base plate	Squareness ( ± μm )	Net Weight (kg)
Second Class	546-0050C2	50	50	40	14	2.5	13	10	26.0	0.05
	546-0075C2	75	75	50	16	2.5	15	13	28.0	0.1
	546-0100C2	100	100	70	20	2.5	18	15	30.0	0.18
	546-0150C2	150	150	100	24	3	22	18	36.0	0.4
	546-0200C2	200	200	130	29	4	26	22	4.0	0.74
	546-0250C2	250	250	165	30	4	26	22	44.0	1.0
	546-0300C2	300	300	200	35	4	32	27	50.0	1.7
	546-0400C2	400	400	204	40	5	40	30	60.0	2.5
	546-0450C2	450	450	280	45	5	40	30	66.0	3.2
	546-0500C2	500	500	300	46	5	45	35	70.0	4.6
	546-0600C2	600	600	325	50	6	55	35	80.0	6.7
	546-0750C2	750	750	400	58	8	63	50	96.0	12.3
	546-1000C2	1,000	1,000	550	65	10	80	65	120.0	29.6
	546-1500C2	1,500	1,500	620	80	10	90	65	170.0	38
546-2000C2	2,000	2,000	830	100	12	105	70	220.0	66.7	
First Class (Hardened)	546-0050CQ	50	50	40	14	2.5	13	10	13.0	0.05
	546-0075CQ	75	75	50	16	2.5	15	13	14.0	0.1
	546-0100CQ	100	100	70	20	2.5	18	15	15.0	0.18
	546-0150CQ	150	150	100	24	3	22	18	18.0	0.4
	546-0200CQ	200	200	130	29	4	26	22	20.0	0.74
	546-0250CQ	250	250	165	30	4	26	22	22.0	1.0
	546-0300CQ	300	300	200	35	4	32	27	25.0	1.7
	546-0400CQ	400	400	204	40	5	40	30	30.0	2.5
	546-0450CQ	450	450	280	45	5	40	30	33.0	3.2
	546-0500CQ	500	500	300	46	5	45	35	35.0	4.6
	546-0600CQ	600	600	325	50	6	55	35	40.0	6.7
	546-0750CQ	750	750	400	58	8	63	50	48.0	12.3
	546-1000CQ	1,000	1,000	550	65	10	80	65	60.0	29.6
	546-1500CQ	1,500	1,500	620	80	10	90	65	85.0	38
546-2000CQ	2,000	2,000	830	100	12	105	70	110.0	66.7	

## Flat -Type Square ( JIS B 7526 )

Stock No.547-1, 547-2

Traceability



- This is essential to measure straightness.
- First class is hardened.

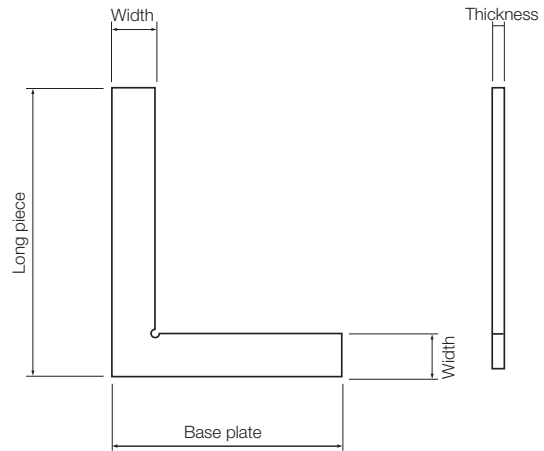

Unit = mm

	Code #	Nominal Size	Long piece	Base plate	Width	Thickness	Squareness ( ± μm )	Net Weight ( kg )
Second Class	547-00502	50	50	40	15	3	26.0	0.04
	547-00752	75	75	50	18	3	28.0	0.05
	547-01002	100	100	70	20	4	30.0	0.08
	547-01502	150	150	100	25	5	36.0	0.22
	547-02002	200	200	130	25	6	40.0	0.35
	547-02502	250	250	165	30	6	44.0	0.54
	547-03002	300	300	200	30	6	50.0	0.66
	547-04002	400	400	200	40	8	60.0	1.4
	547-04502	450	450	235	40	8	66.0	1.62
	546-05002	500	500	300	46	8	70.0	1.91
	546-06002	600	600	300	50	10	80.0	3.3
	546-07502	750	750	400	58	10	96.0	4.3
	546-10002	1,000	1,000	550	65	12	120.0	8.4
	546-15002	1,500	1,500	750	80	14	170.0	19.1
546-20002	2,000	2,000	1,000	100	16	220.0	36.3	
First Class (Hardened)	546-0050Q	50	50	40	14	3	13.0	0.04
	546-0075Q	75	75	50	16	3	14.0	0.05
	546-0100Q	100	100	70	20	4	15.0	0.08
	546-0150Q	150	150	100	25	5	18.0	0.22
	546-0200Q	200	200	130	25	6	20.0	0.35
	546-0250Q	250	250	165	30	6	22.0	0.54
	546-0300Q	300	300	200	30	6	25.0	0.66
	546-0400Q	400	400	200	40	8	30.0	1.4
	546-0450Q	450	450	235	40	8	33.0	1.62
	546-0500Q	500	500	300	40	8	35.0	1.91
	546-0600Q	600	600	300	50	10	40.0	3.3
	546-0750Q	750	750	400	50	10	48.0	4.3
	546-1000Q	1,000	1,000	550	60	12	60.0	8.4
	546-1500Q	1,500	1,500	750	80	14	85.0	19.1
546-2000Q	2,000	2,000	1,000	100	16	110.0	36.3	

## I -Type Precision Square ( JIS B 7526 )

Stock No.548-1, 548-2

Traceability

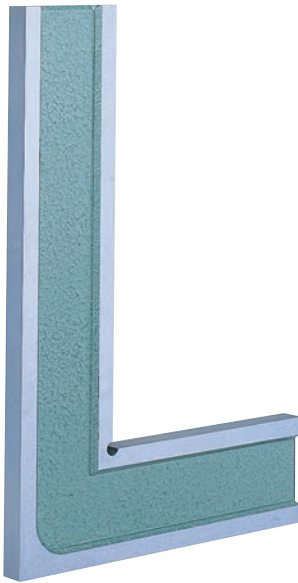

- This has the highest accuracy among the squares.  
( Only First Class )
- Hardened, grinded and lapped finish.
- All size is hardened.
- Use it as a standard of all squares.

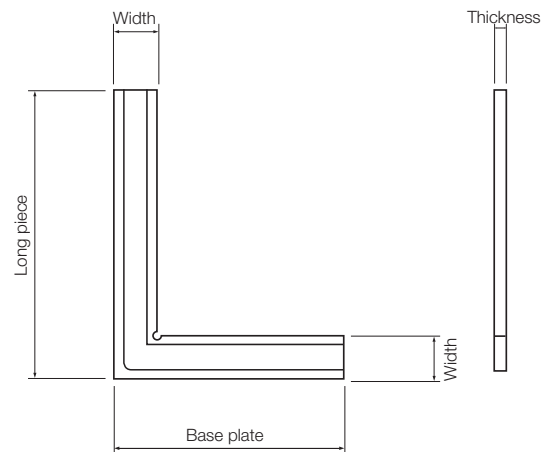

Unit = mm

	Code #	Nominal Size	Long piece	Base plate	Width	Thickness	Squaremess ( ± μm )	Net Weigt (kg)
Second Class	548-00502	50	50	40	16	4	6.0	0.04
	548-00752	※ 75	75	50	18	4	6.5	0.07
	548-01002	※ 100	100	70	25	6	7.0	0.25
	548-01502	※ 150	150	100	30	8	8.0	0.5
	548-02002	※ 200	200	130	35	10	9.0	1.0
	548-02502	250	250	165	40	10	10.0	1.5
	548-03002	※ 300	300	200	40	15	11.0	2.5
	548-05002	※ 500	500	300	55	20	15.0	5.2
	548-06002	600	600	350	60	23	17.0	7.5
First Class	548-00501	50	50	40	16	4	2.50	0.04
	548-00751	75	75	50	18	4	2.80	0.07
	548-01001	100	100	70	25	6	3.0	0.25
	548-01501	150	150	100	30	8	3.50	0.5
	548-02001	200	200	130	35	10	4.0	1.0
	548-02501	250	250	165	40	10	4.50	1.5
	548-03001	300	300	200	40	15	5.0	2.5
	548-05001	500	500	300	55	20	7.0	5.2
548-06001	600	600	350	60	23	8.0	7.5	

## Precision Thick Type Square

Stock No.549 Traceability



- This is a stable scale having thick base and column.
- All size is hardened.

Unit = mm

Code #	Nominal Size	Long piece	Base plate	Width	Thickness	Squareness ( $\pm \mu\text{m}$ )	Net Weight (kg)
549-050	50	50	40	15	10	13.0	0.1
549-075	75	75	50	18	12	14.0	0.2
549-100	100	100	70	20	15	15.0	0.4
549-125	125	125	80	20	15	16.0	0.5
549-150	150	150	100	25	20	18.0	0.9
549-200	200	200	130	30	20	20.0	1.4
549-250	250	250	145	35	25	23.0	2.5
549-300	300	300	170	35	25	25.0	3.0

## Knife Edged Standard Square [ I type]

Stock No.550 Traceability



- Its external angle is sharpened like a knife, the light coming from the gap between this square and object tells an error in squareness.
- All size is hardened.

Unit = mm

Code #	Nominal Size	Long piece	Base plate	Width	Thickness	Squareness ( $\pm \mu\text{m}$ )	Net Weight (kg)
550-0503	50	50	40	12	8	2.5	0.1
550-0753	75	75	50	16	10	2.8	0.2
550-1003	100	100	70	20	12	3.0	0.35
550-1503	150	150	100	24	14	3.5	0.7
550-2003	200	200	130	29	16	4.0	1.2
550-2503	250	250	165	32	16	4.5	2.0
550-3003	300	300	200	35	20	5.0	2.5

## Knife Edged Standard Square [ III Type ] ( JIS B7526 )

Stock No.550-III

[Traceability](#)



- Both external and internal angles are shaped like a knife.
- All size is hardened.

Unit = mm

Code #	Nominal Size	Long piece	Base plate	Width	Thickness	Squareness ( ± μm )	Net Weight (kg)
555-050	50	50	40	15	4	2.5	0.09
555-075	75	75	50	20	5	2.8	0.2
555-100	100	100	70	25	6	3.0	0.27
555-150	150	150	100	30	8	3.5	0.5
555-200	200	200	130	35	10	4.0	1.1
555-250	250	250	165	35	10	4.5	1.8
555-300	300	300	200	40	15	5.0	2.3

## Cylindrical Square ( JIS B7539 )

Stock No.551

[Traceability](#)



- This has the highest accuracy among the squares.
- All size is hardened.

※ The handle of the size smaller than 300mm types cannot be detached.

Unit = mm

Code #	Nominal Size	Height	Diameter	Squareness ( ± μm )	Net Weight (kg)
551-0100Q	100	100	60	2.5	2.5
551-0150Q	150	150	70	2.8	4.9
551-0200Q	200	200	80	3.0	8.3
551-0250Q	250	250	90	3.3	13
551-0300Q	300	300	100	3.5	17
551-0350Q	350	350	110	3.8	19.4
551-0400Q	400	400	120	4.0	21
551-0500Q	500	500	130	4.5	30.5
551-0600Q	600	600	160	5.0	48
551-0800Q	800	800	200	6.0	84
551-1000Q	1000	1000	240	7.0	170
551-1200Q	1200	1200	250	8.0	190

**About accuracy of SQUARE**

Type	Class	Calculating Squareness
Cyrindrial Square		$\pm ( 2+ \ell /200 ) \mu\text{m}$
Knife Edged Standard Square	—	$\pm ( 2+ \ell /100 ) \mu\text{m}$
I -Type Precision Square	First Class	
I -Type Precision Square	Second Class	$\pm ( 5+ \ell /50 ) \mu\text{m}$
Flat Type Squae	First Class	$\pm (10+ \ell /20 ) \mu\text{m}$
Precision Square with Base		
Graduated Precision Square	—	
Precision Thick Square		
Flat Type Squae	Second Class	$\pm ( 20+ \ell /10 ) \mu\text{m}$
Precision Square with Base		

**About accuracy of STRAIGHT EDGE**

Type	Class	Calculating Straightness
Knife-Type Straight Edge	—	$\pm ( 1+ \ell /250 ) \mu\text{m}$
Precision Straight Edge I Type	Class A	$\pm ( 2+ \ell /250 ) \mu\text{m}$
Precision Straight Edge		
Wide-Type Highest Grade Straight Edge		
I Beam Type Highest Grade Straight Edge	Class A	$\pm ( 2+ \ell /100 ) \mu\text{m}$
Standard Steel Straight Edge		
Wide-Type Highest Grade Straight Edge	Class B	$\pm ( 4+ \ell /50 ) \mu\text{m}$
Precision Straight Edge I Type		
Precision Straight Edge		
Steel Straight Edge Bevel Type	—	$\pm (10+ \ell /50 ) \mu\text{m}$
Steel Straight Edge Normal Type		